

MINI SCORPIO HEAD

User Manual



Contents table

1.- DESCRIPTION	5
2.- MODULES.....	7
2.1.- PAN module.....	7
2.2.- TILT module.....	9
2.3.- ROLL module.....	11
2.3.1.- <i>Camera platform mount</i>	13
2.3.2.- <i>Camera platform</i>	15
2.4.- Risers	16
2.5.- Supports	17
2.5.1.- <i>“2 axis” support</i>	17
2.5.2.- <i>3D support</i>	19
2.5.3.- <i>“3 axis” support</i>	20
2.6 Connector PIN OUTs	21
3.- CONFIGURATIONS	27
3.1.- “2 axis”	27
3.2.- “3 axis”	28
4.- OPTIONS	29
4.1.- Triax and HD.....	29
5.- CONTROLS	30
5.1.- “interface” screen	30
5.2.- Connections.....	31
5.3.- Joystick.....	35
5.4.- Handwheels	38
5.5.- Pan bar (JDR).....	44
5.6.- Handheld	51
6.- SET UP.....	55
6.1 Mounting the head	55
6.2 Mounting the camera	57
6.3 Cable connections	61
6.3.1 <i>Power</i>	61
6.3.2 <i>Communication</i>	62
6.3.3 <i>Video signal</i>	63

1.- Description

The Mini Scorpio Head is a two or three axis remote head designed by Service Vision. It is used to support and move all types of cameras. All of its axes incorporate ultra precise mechanical movement transmission systems, individual digital control servos and slip rings. The slip rings permit free 360° movement, transmit the head control, camera and head power, Triax signals, composite video signals and HD signals.

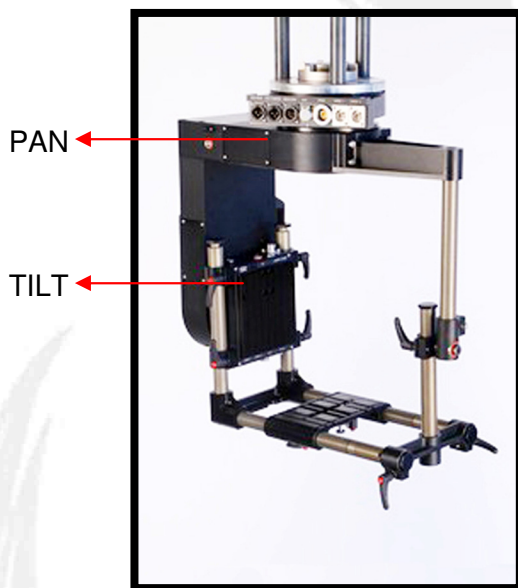

2 Axis

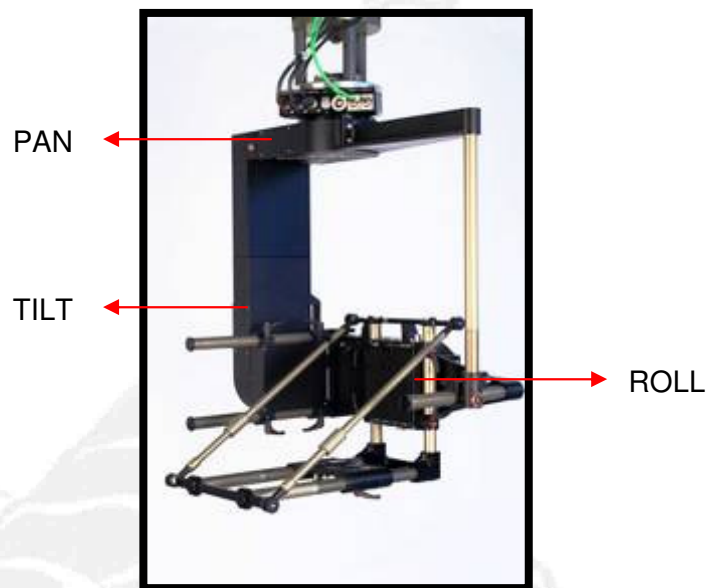

3 Axis

The Mini Scorpio Head has been designed in a modular way. This makes it a very versatile head that can enter into small places or house a 3D rig with two cameras.

The remote control systems available are the Hand Wheels, Pan Bar (JDR), Joystick and Handheld.



Hand Wheels



Pan bar (JDR)



Joystick



Handheld

The communication between the control desk and the head can be made up to 1 Km by cable or, depending on the antenna used, 900m with the Scorpio Radio modules.

The Mini Scorpio Head is compatible with all the other Scorpio products designed and manufactured by Service Vision.

2.- Modules

2.1.- PAN module

The PAN module is the one that allows us to turn 360° horizontally.

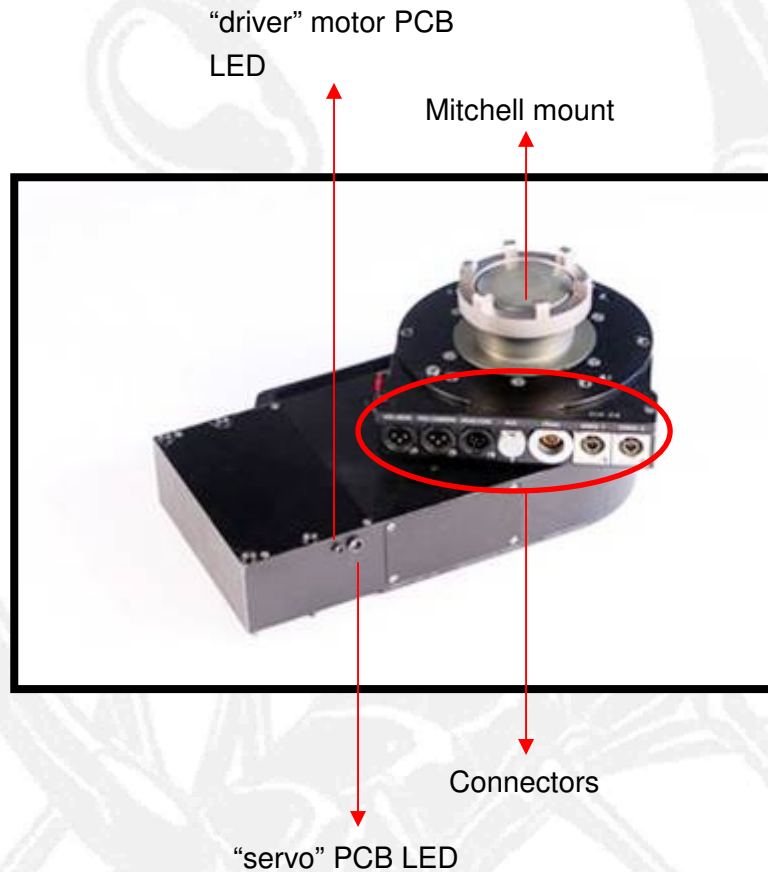

It is also the axis which connects the head to the support (crane, dolly, travelling, etc). A Mitchell Mount is used for the union between the head and the support.

The Standby button and all the connectors are situated on the top, moving, part (just below the Mitchell Mount).

Connector descriptions:

Red button: disconnects the power so that the head can be moved freely.



- Video 2
(BNC-CANARE BCJ-RU)
- Video 1
(BNC-CANARE BCJ-RU)
- HD/TRIAX
(TRIAX-LEMO, ERA 3T.675.CTL)
- Aux.
(LEMO, 10 pin female, EGG.2B.310)
- Head COM
(NEUTRIK, 6 pin male, panel mount, NC6MDL1-B)
- VDC Camera
(NEUTRIK, 3 pin male, panel mount, NC3MDL1-B)
- VDC Head
(NEUTRIK, 3 pin male, panel mount, NC3MDL1-B)

Inter-module connector
(DB37 female)



HD/TRIAX
(LEMO, 3 pin male, FFA.1S.650.CTAC52)

2.2.- TILT module

When the head is configured in “3 axis”, the TILT module allows us to rotate 360° in the vertical plain. This axis is not used in the “2 axis” configuration as the ROLL axis is used to do the tilt functions.

Motor “driver” PCB LED

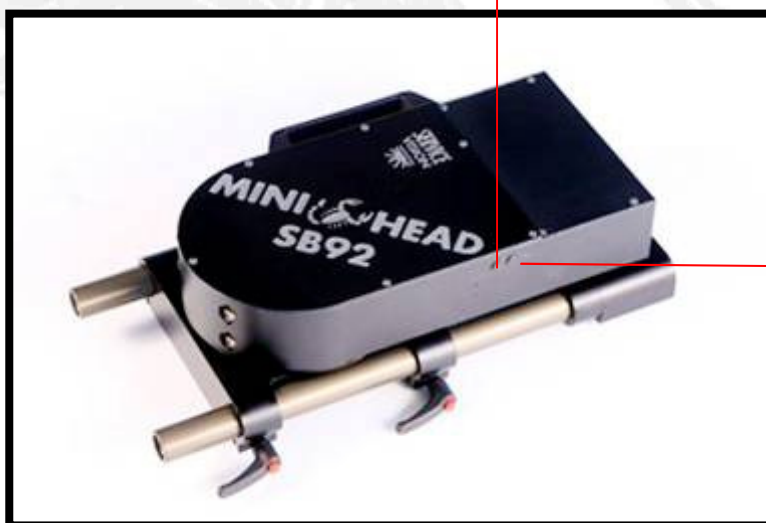

“servo” PCB LED

This axis does not have any accessible external connection. Signal and power are both passed from the PAN to the ROLL axis through the two connectors which are situated on either end of the TILT module.

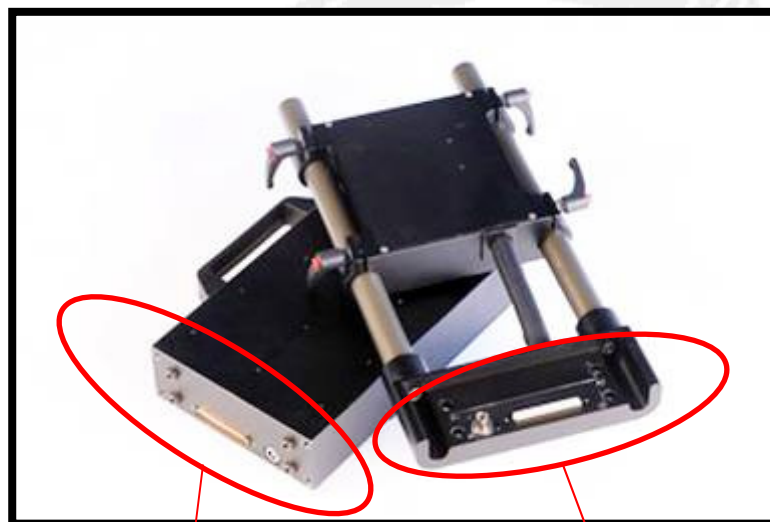

HD/TRIAX
(LEMO, 3 pin female, ERA.1S.650.CTL)

Inter-module connector
(DB37 male)

HD/TRIAX
(LEMO, 3 pin male, EFA.1S.650.CTAC52)

Inter-module connector
(DB37 female)

2.3.- ROLL module

The Roll module allows us to rotate 360° dutch (circular) and vertical when connected in three axis and two axis respectively.

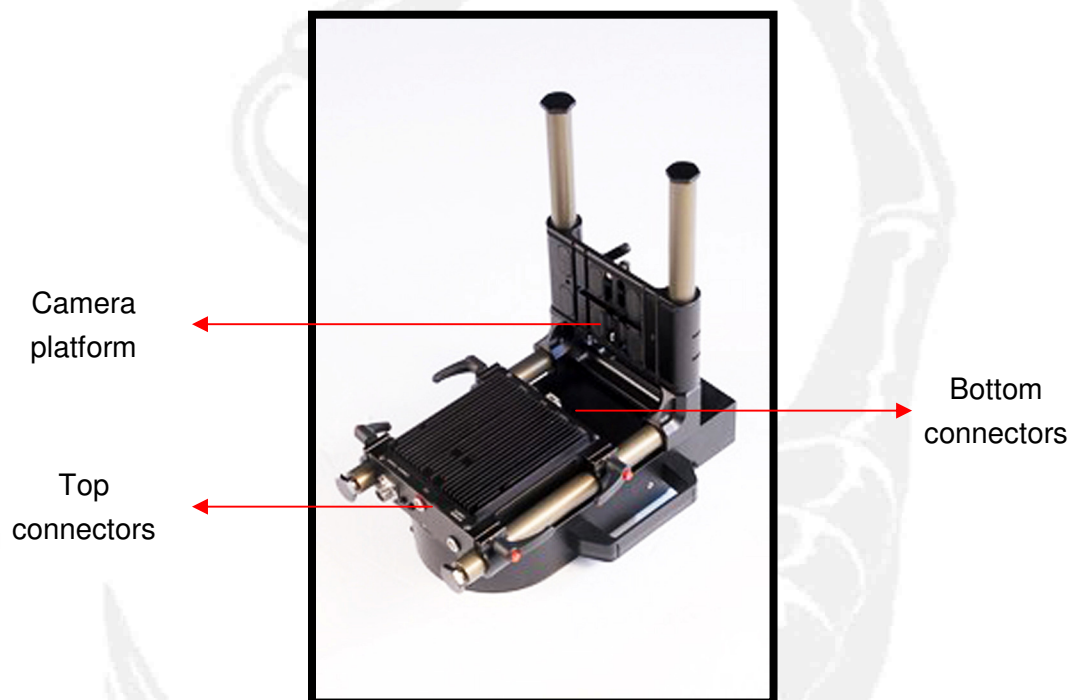

All the connectors for the camera are situated on this axis.

Connector descriptions:

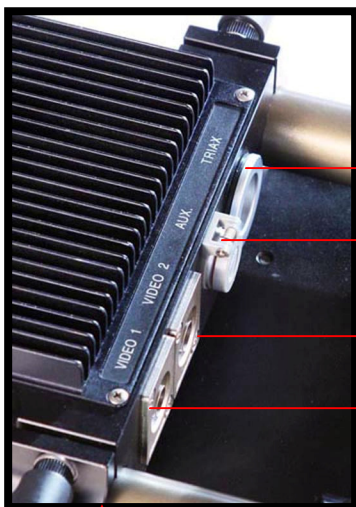

- HD/TRIAX
(TRIAX-LEMO, ERA 3T.675.CTL)
- Aux.
(LEMO, 10 pin female, EGG.2B.310)
- Video 2
(BNC-CANARE BCJ-RU)
- Video 1
(BNC-CANARE BCJ-RU)

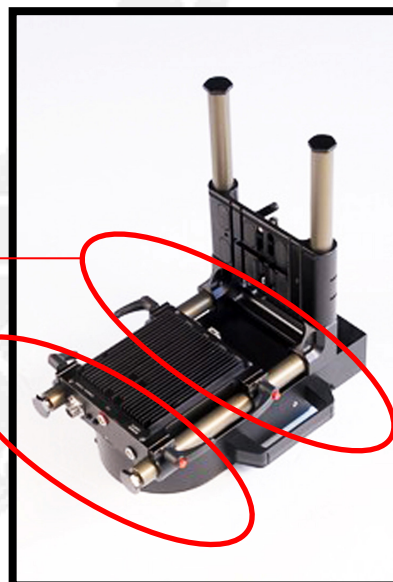

Camera power LEDs

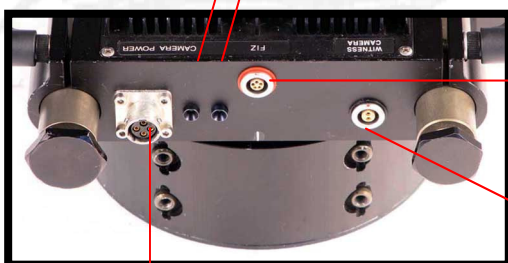

- FIZ power
(LEMO, 5 pin female, panel mount, EGG.1B.305)
- Witness camera power
(LEMO, 2 pin female)

Camera power
(BURNDY, 4 pin female, panel mount, UT00104ST)

2.3.1.- Camera platform mount

The camera support platform is a “L” made from rods which allows us to hold the camera at 90° to the ROLL axis. This support is the same for the two and three axis head configurations.

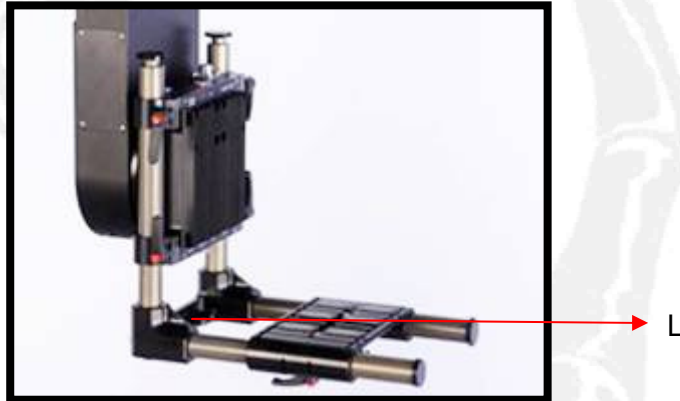

In the three axis configuration 180mm extension rods are added. Two black flat bars are used to join the rods at the top and bottom. The top flat bar and the bottom flat bar must be put on the top and bottom of the “L” respectively. Lastly, the flat bars are joined on each side by the corresponding tension rod. These tension rods must be fastened and tensioned before the camera is mounted.

Right hand tensor

Left hand tensor

Extension rods for three axis configuration (180mm)



Upper flat bar

Lower flat bar



To mount the tensors the black flat bars must be mounted first. These bars are different to each other and have a specific position. The “U” shaped flat bar is mounted on top where the ROLL connectors are accessed, thereby giving space for the cables to be plugged in.

Once the flat bars have been mounted the tension rods are de-tensioned and both ends are fastened to the flat bars at the same time. Then they can be tensioned until the limit at which they can be locked is reached.

On one of the tension rods (the one that is always mounted on the left) there is a permanently mounted bracket which is used to hold the lens control device.

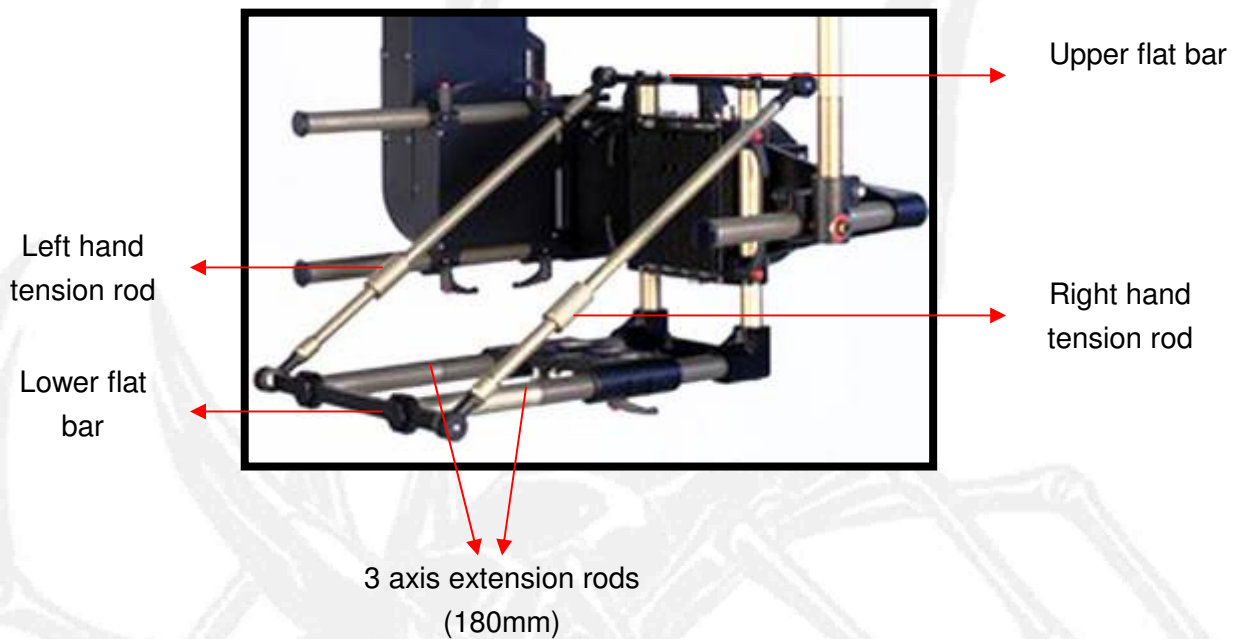

In the two axis configuration the lens control is mounted on the end of one of the “L” s vertical rods.

2.3.2.- Camera platform

The camera platform is the same for the two and three axis configurations. In two axis the camera is mounted parallel to the platform. In three axis the camera is mounted perpendicular to the platform.

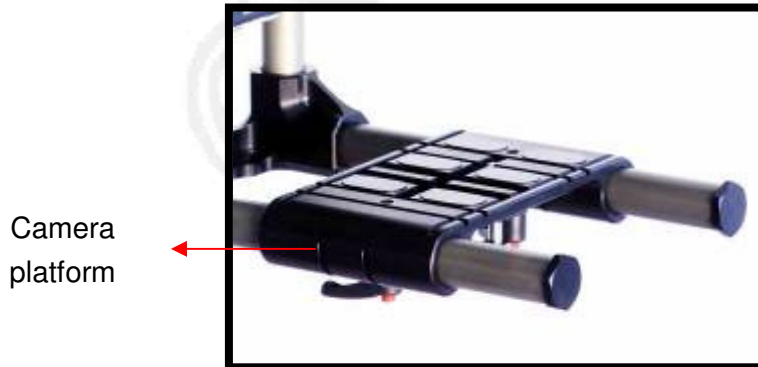

In the three axis configuration there are two slots for mounting the camera. They depend on whether 15 or 19mm bar accessories are being used.

20mm screws are used for cameras that do not need a motor mounting plate and 33mm screws are used in the case that a plate is necessary.



2.4.- Risers

A riser is an aluminium extension that allows us to make the head bigger in the two or three axis configurations.

There are two types of risers: 100mm and 200mm.

100 mm riser.

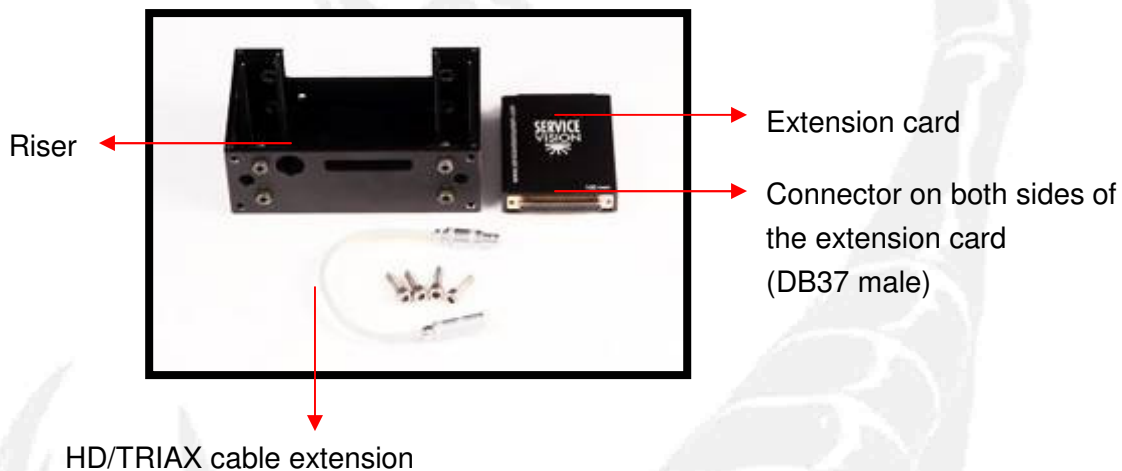

200 mm riser.

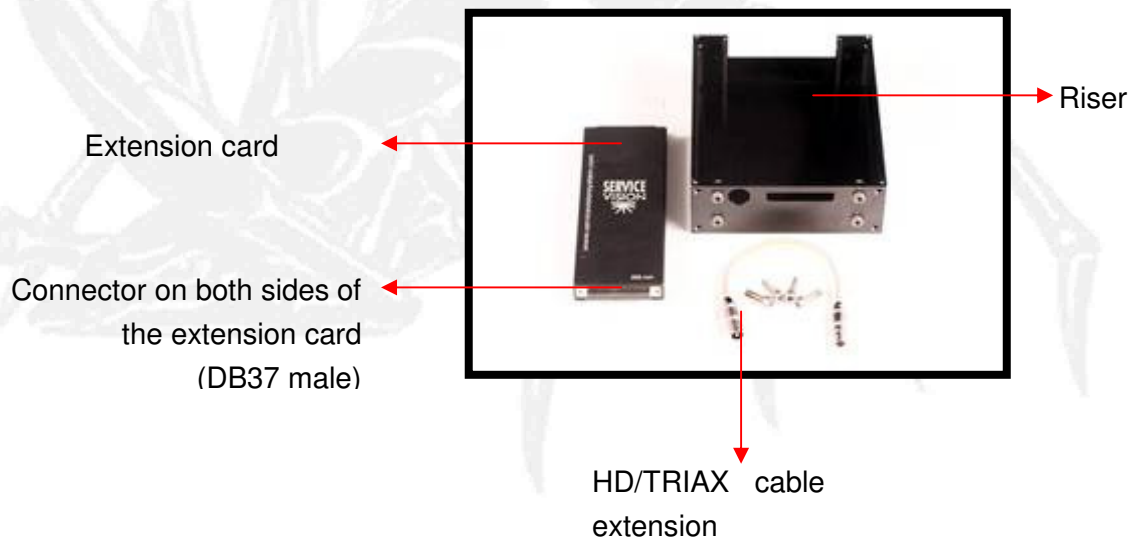

Both risers house an extension card. The extension card is a printed circuit board that links the electronics and cabling between the axes.

The risers are connected to the head with screws.

2.5.- The Camera Cradle

We consider the Camera Cradle to be the arrangement of rods opposite to the TILT axis which encloses the head. In the case of the three axis configuration it is mandatory where as in the two axis case it is optional.

2.5.1.- The Camera Cage “2 axis”

When the head is in the two axis configuration the open side can be closed to give it more stability, strength and some weight compensation when the PAN axis is turned.

In two axis the following pieces are needed to mount the Camera Cradle:



When a riser is added in both the two and three axis configurations a rod of the SAME size is added.

To mount the camera cradle in two axis the “L” (camera support mount) has to be lengthened with the 104.8mm extension rods. Then the “T” is mounted onto it and joined to the small triangle via the swivel.

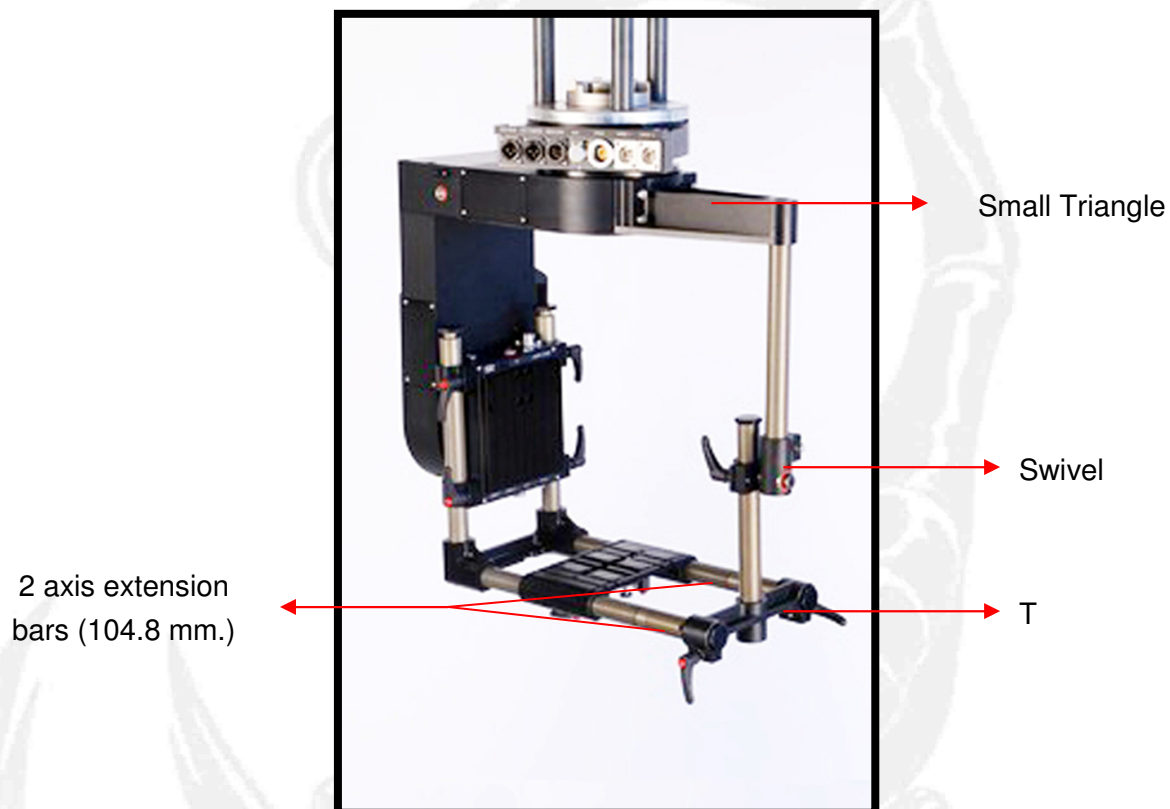

It is very important that the swivel is properly fitted onto the bottom of the small triangle's bar to ensure a smooth movement of the TILT axis.

2.5.2.- 3D Camera Cradle

Depending on the 3D rig used the camera cradle can be made bigger accordingly. The process will be the same as before except that a series of precise bars are used for each rig.

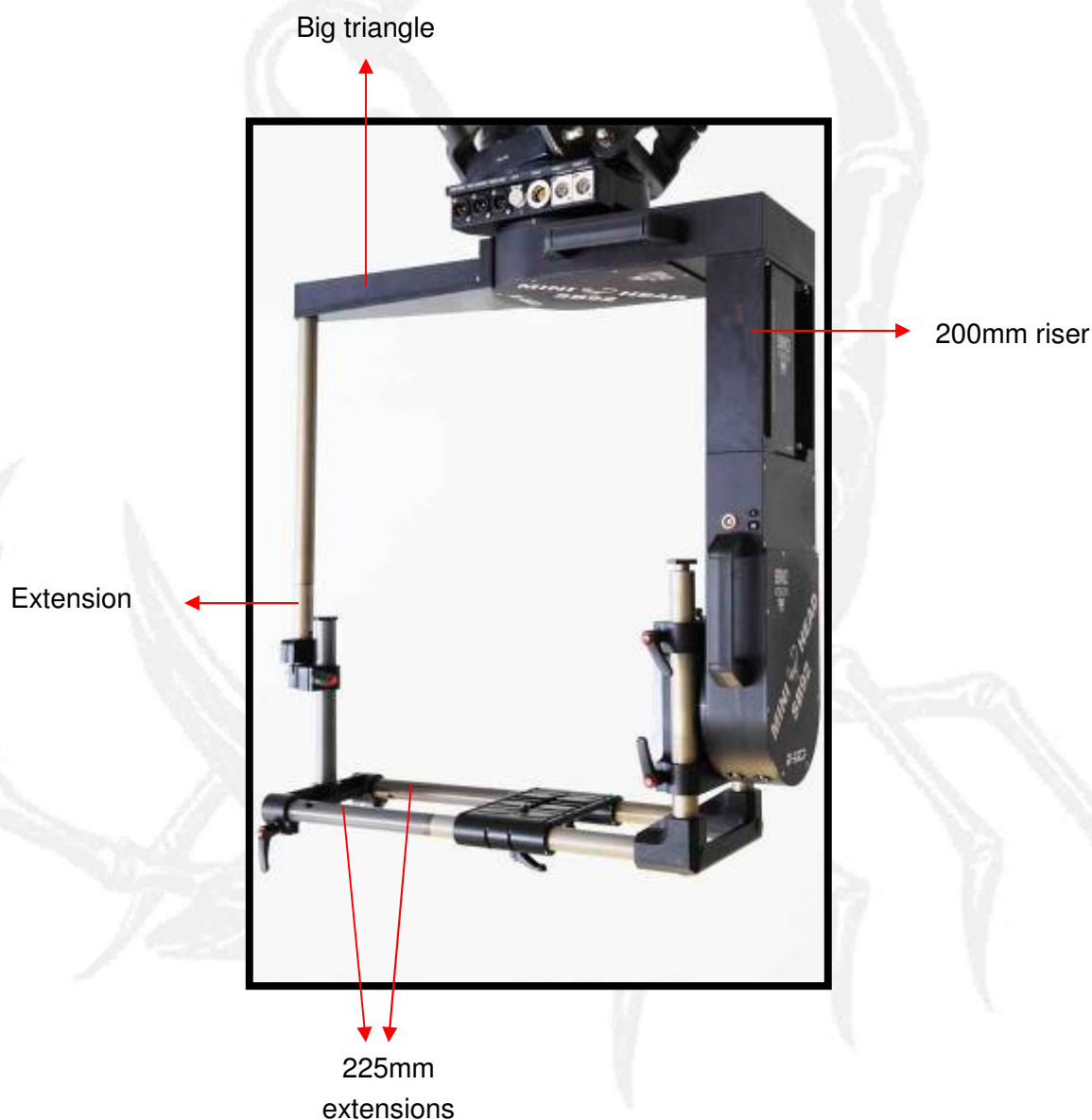

The extension that is mounted on the small triangle's rod will be directly linked to the riser being used. For example, when a 100mm riser is used a 100mm extension rod will be used, when a 200mm riser is used the size of the extension rod will be 200mm and if no riser is used no extension rod will be necessary.

2.5.3.- "3 axis" Camera Cradle

In three axis the following pieces are needed to mount the Camera Cradle:

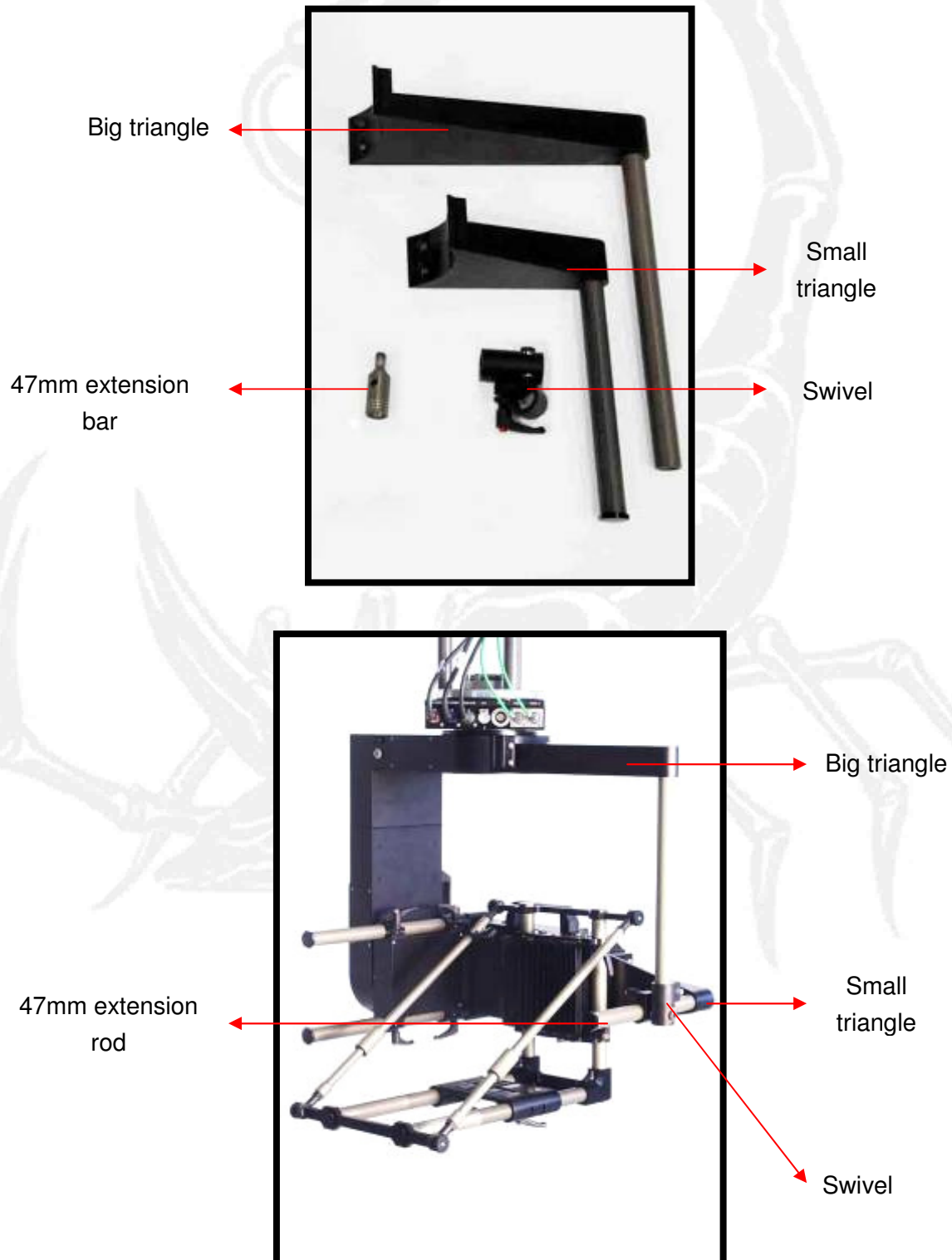

2.6 Connector PIN OUTs

Aux.

(LEMO, 10 pin female, EGG.2B.310)

D1 NC
D2 NC
D3 NC
D4 NC
D5 NC
D6 NC
D7 NC
D8 NC
D9 NC
D10 NC

Camera power

(BURNDY, 4 pin female, panel mount, UT00104ST)

A VCC OUT 12V Red
B GND Black
C VCC OUT 12V Blue
D GND White

Inter-module connector

(DB37 female)

- 1 VCC +30V Camera (black)
- 2 VCC +30V Camera (black)
- 3 VCC +30V Camera (black)
- 4 GND Camera line (black)
- 5 GND Camera line (black)
- 6 NC
- 7 VCC +30V Head (black)
- 8 VCC +30V Head (black)
- 9 GND Camera line (black)
- 10 GND Camera line (black)
- 11 Aux. 2 Brown
- 12 Aux. 4 Yellow
- 13 Aux. 6 Pink
- 14 Aux. 8 Red
- 15 Aux. 10 Purple
- 16 Head comm. RX Red-Blue
- 17 GND Video 1
- 18 Active Video 1
- 19 GND Video 1
- 20 VCC +30V Camera (black)
- 21 VCC +30V Camera (black)
- 22 GND Camera line (black)
- 23 GND Camera line (black)
- 24 GND Camera line (black)
- 25 VCC +30V Head (black)
- 26 VCC +30V Head (black)
- 27 GND Camera line (black)
- 28 GND Camera line (black)
- 29 Aux. 1 White
- 30 Aux. 3 Green
- 31 Aux. 5 Gray
- 32 Aux. 7 Blue
- 33 Aux. 9 Black
- 34 Head comm. RX Pink-Gray
- 35 GND Video 2
- 36 Active Video2
- 37 GND Video 2

Inter-module connector

(DB37 male)

- 1 VCC +30V Camera (black)
- 2 VCC +30V Camera (black)
- 3 VCC +30V Camera (black)
- 4 GND Camera line (black)
- 5 GND Camera line (black)
- 6 NC
- 7 VCC +30V Head (black)
- 8 VCC +30V Head (black)
- 9 GND Camera line (black)
- 10 GND Camera line (black)
- 11 Aux. 2 Brown
- 12 Aux. 4 Yellow
- 13 Aux. 6 Pink
- 14 Aux. 8 Red
- 15 Aux. 10 Purple
- 16 Head comm. RX Red - Blue
- 17 GND Video 1
- 18 Active Video 1
- 19 GND Video 1
- 20 VCC +30V Camera (black)
- 21 VCC +30V Camera (black)
- 22 GND Camera line (black)
- 23 GND Camera line (black)
- 24 GND Camera line (black)
- 25 VCC +30V Camera (black)
- 26 VCC +30V Camera (black)
- 27 GND Camera line (black)
- 28 GND Camera line (black)
- 29 Aux. 1 White
- 30 Aux. 3 Green
- 31 Aux. 5 Gray
- 32 Aux. 7 Blue
- 33 Aux. 9 Black
- 34 Head comm. RX Red - Gray
- 35 GND Video 2
- 36 Active Video2
- 37 GND Video 2

FIZ power

(LEMO, 5 pin female, panel mount, EGG.1B.305)

- 1 VCC OUT 30V Red
- 2 GND Black
- 3 485A Gray – Pink
- 4 485B Red – Blue
- 5 NC

HD/TRIAX

(LEMO, 3 pin male, EFA.1S.650.SCTAC52)

- 1 ACTIVE
- 2 INT GND
- 3 EXT GND

HD/TRIAX

(LEMO, 3 pin female, ERA.1S.650.CTL)

- 1 ACTIVE
- 2 INT GND
- 3 EXT GND

HD/TRIAX

(TRIAX-LEMO, ERA 3T.675.CTL)

- 1 ACTIVE
- 2 INT GND
- 3 EXT GND

Head COM

(NEUTRIK, 6 pin male, panel mount, NC6MDL1-B)

- 1 NC
- 2 GND Black
- 3 GND Black
- 4 VCC OUT+30V Red
- 5 485B- Red
- 6 485A- White

Power Witness camera

(LEMO, 2 pin female)

- 1 VCC 12V
- 2 GND

VDC Camera

(NEUTRIK, 3 pin male, panel mount, NC3MDL1-B)

- A1 VCC IN 28V Black
- A2 GND Black
- A3 NC

VDC Head

(NEUTRIK, 3 pin male, panel mount, NC3MDL1-B)

- A1 VCC IN 28V Black
- A2 GND Black
- A3 NC

Video 1

(BNC-CANARE BCJ-RU)

- 1 Video
- 2 GND

Video 2
(BNC-CANARE BCJ-RU)

1 Video
2 GND

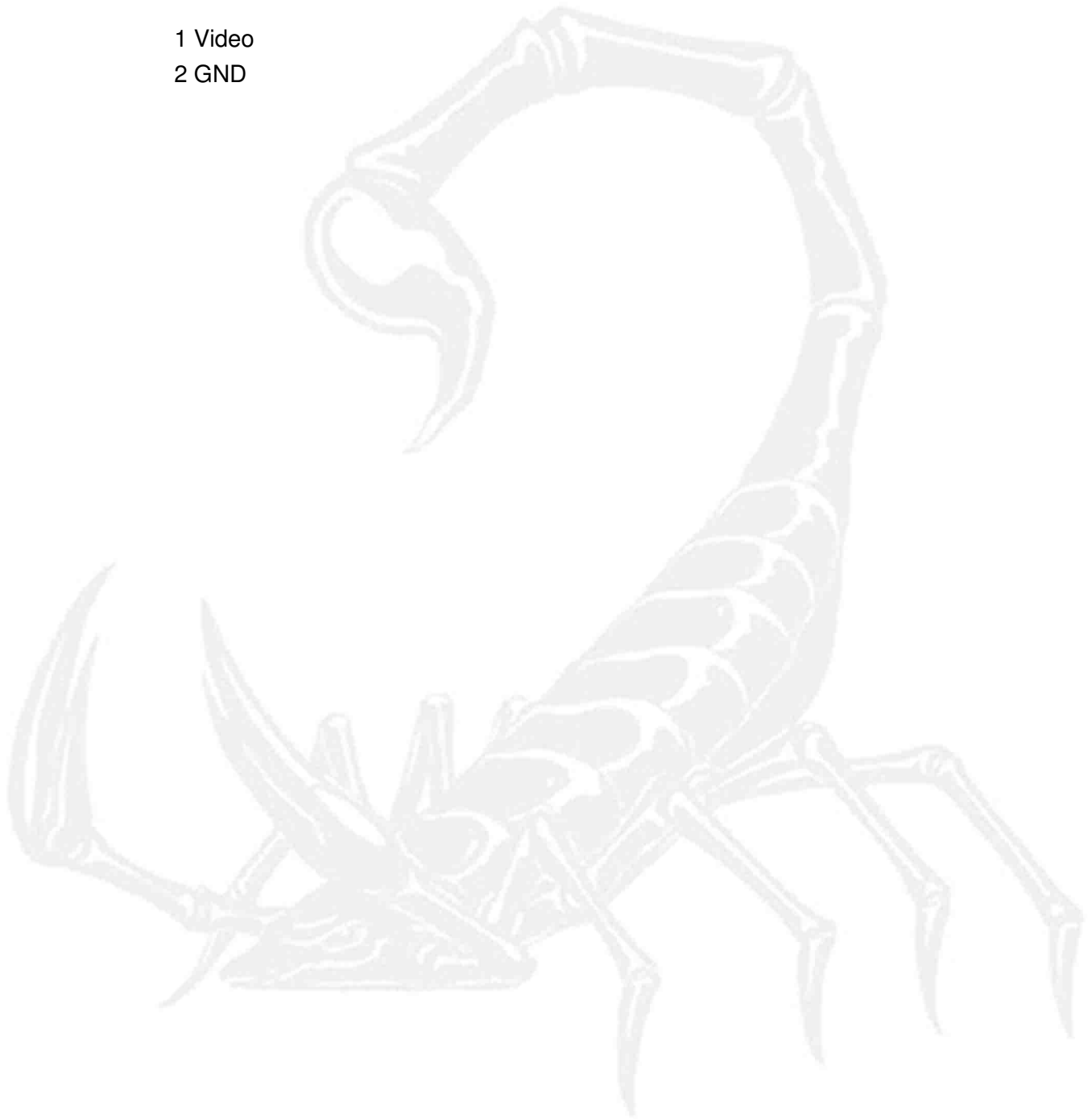

3.- Configurations

The Mini Scorpio has two configurations that are recognised by the system but it is also true that one axis can work on its own. The standard configurations are two and three axis. Both allow for a specific variation in the TILT axis size.

3.1.- “2 Axis”

The two axis configuration allows for a movement in the PAN and TILT axes. In this configuration the TILT axis can be connected directly to the PAN axis thus reducing the size or by adding a riser the TILT axis can be made longer thus giving more vertical camera movement.



100 Riser



200 Riser



100+200 Risers

When a riser is added a rod of the same length must be added to the triangle rod to equal the lengths on both sides.

3.2.- “3 Axis”

The three axis configuration allows for a movement in the PAN, TILT and ROLL axes. As with the two axis configuration the TILT axis's height can be regulated depending on the amount of movement needed.



In this configuration the minimum riser that can be connected between the PAN and the TILT axes is the 100mm. The 200mm or both can also be used.



200 Riser



100+200 Riser

In this case the big triangle extension rod will be 100mm less than the riser in use.

4.- Options

The Mini Scorpio Head has different interior connection options. These options are of origin and can only be modified in the factory.

4.1.- Triax y HD

Triax is a connection used in Television that transmits all camera controls via special Triax slip rings. These include the image signal and camera power. These slip rings are independent of the principle slip rings.

The inter-module connections are done with triaxial cable. They can transmit HD signal.

With this option various cables are made which connect the standard Triax on the head to different connectors used in the market.

When we want to transit HD signal through the head we will use these same Triax connectors. In this case a Triax-BNC adaptor cable that is supplied will be used with the equipment that has been prepared for HD transmission. This equipment is identified from the rest by the letters “HD” engraved on each of the axes.



MINI SCORPIO lid
(with HD)

MINI SCORPIO lid
(without HD)

5.- Controls

There are four types of control desks for the Mini Scorpio Head. They all have the same “interface” screen, the same control software and the same connections. First of all we are going to define two of these similarities.

5.1.- “interface” Screen

The control desk “interface” can be divided into two parts. The first is the display and buttons that are situated around the screen. They are used to interact with the program. The second is the potentiometers situated at the bottom of the screen that are used to define motion variables for the head.

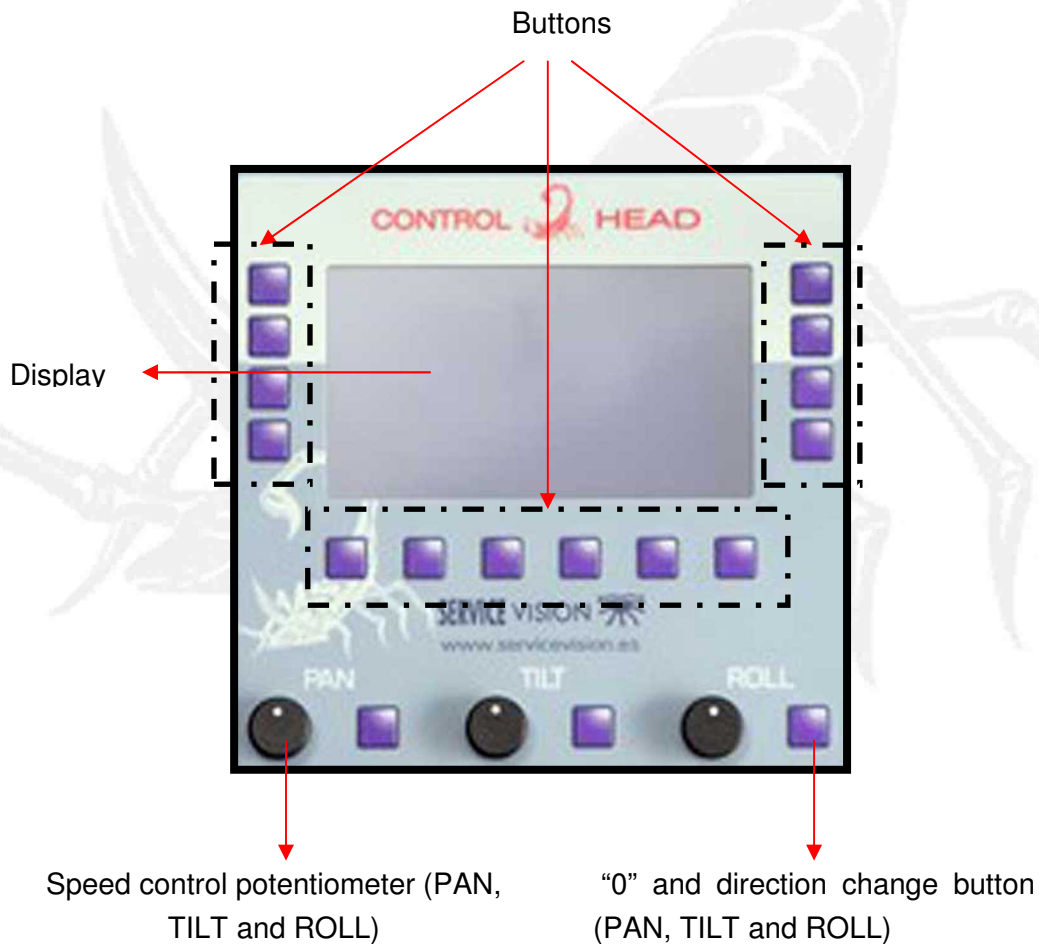

5.2.- Connections

All of the control desk's connections are the same. In some cases there are small exceptions which will be show later in this section.

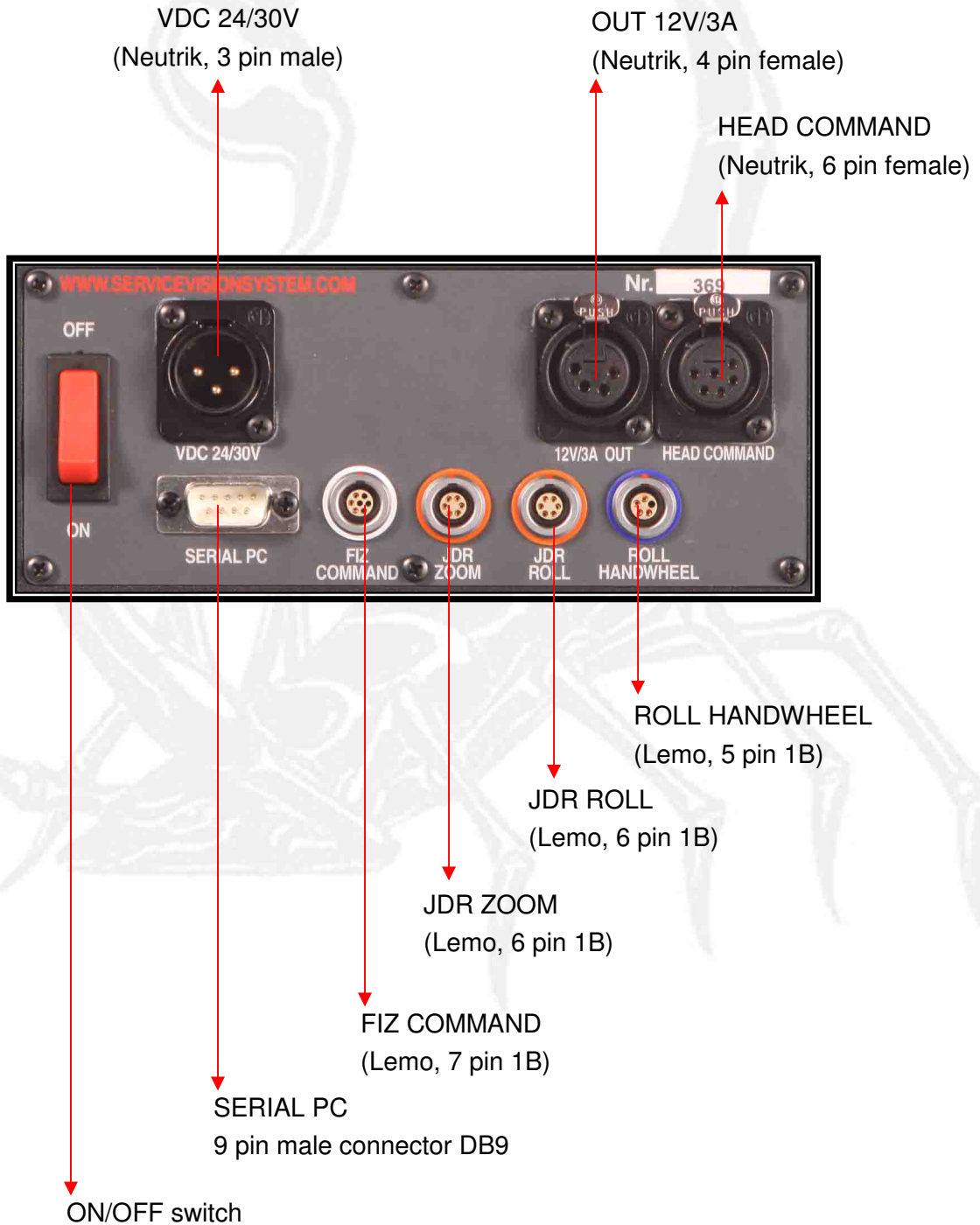

VDC 24/30V

(Neutrik, 3 pin male)

- 1 VCC IN 30V Red
- 2 GND Black
- 3 NC

12V/3A

(Neutrik, 4 pin female)

- 1 GND Black
- 2 NC
- 3 NC
- 4 VCC OUT +12V 3A Red

HEAD COMMAND

(Neutrik, 6 pin female)

- 1 NC
- 2 GND Black
- 3 NC
- 4 VCC OUT +30V Red
- 5 485B Gray
- 6 485A Pink

ROLL HANDWHEEL

(Lemo, 5 pin 1B)

- 1 VCC OUT +5V White
- 2 GND Brown
- 3 ENC A ROLL White - Gray
- 4 ENC B ROLL Yellow - Blue
- 5 NC

JDR ROLL

(Lemo, 6 pin 1B)

- 1 VCC OUT +5V Red
- 2 GND Black
- 3 FOCUS Orange
- 4 ROLL White - Blue
- 5 IN1 Yellow - Pink
- 6 IN0 Yellow - Black

JDR ZOOM

(Lemo, 6 pin 1B)

- 1 VCC OUT +5V Red
- 2 GND Black
- 3 IRIS White - Green
- 4 ZOOM White - Pink
- 5 IN2 White - Red
- 6 IN3 White - Orange

FIZ COMMAND

(Lemo, 7 pin 1B)

- 1 VCC OUT +30V Red
- 2 GND Black
- 3 485A Yellow - Green
- 4 485B Yellow - Blue
- 5 NC
- 6 NC
- 7 NC

Serial PC

9 pin male connector DB9

- 1 NC
- 2 RX 232 Yellow - Red
- 3 TX 232 Yellow - Brown
- 4 NC
- 5 PC GND Green
- 6 NC
- 7 NC
- 8 NC
- 9 NC

All the control desk's connections are similar except that in some not all of the connectors are use because they are not necessary for functionality of that control:

- The handwheels have all the connectors
- The Pan Bar and the Handheld do not have the ROLL HANDWHEEL connector
- The Joystick control does not have the ROLL HANDWHEEL and JDR ZOOM connectors.

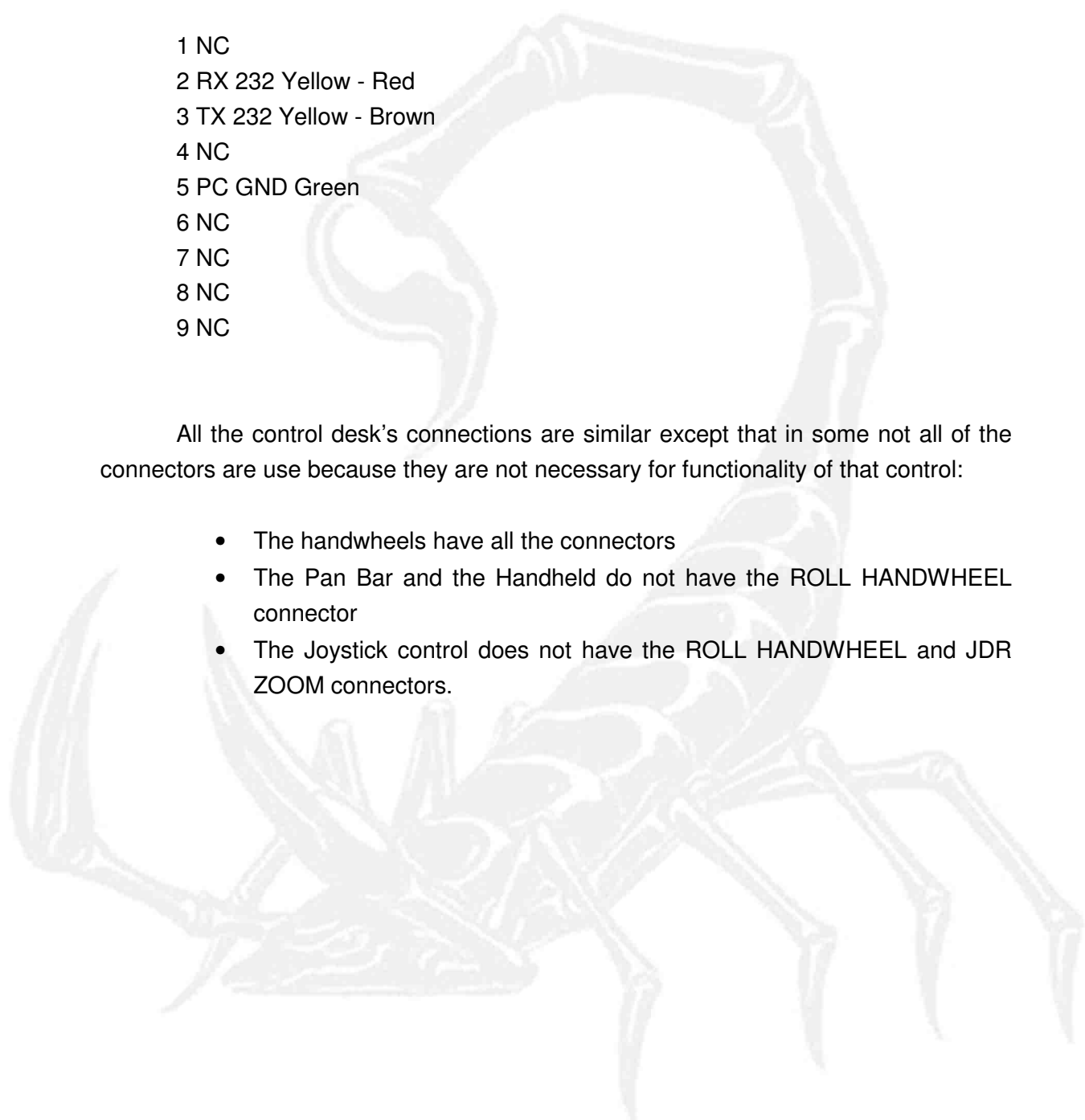

5.3.- Joystick

The joystick, like the other control desks, allows full control of the head (PAN, TILT and ROLL) and the camera functions: IRIS, FOCUS, ZOOM and zoom speed.



The number of controls can be amplified with accessories for eg. the pedal which is connected to the JDR ROLL.

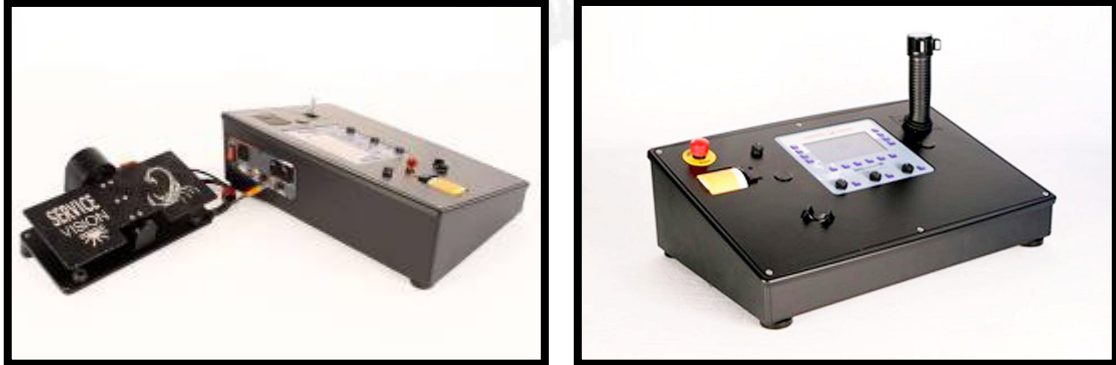

Transport case



Connections



5.4.- Handwheels

This control desk has three handwheels which are assigned to the three axes, PAN, TILT and ROLL. In the case that the head is working in two axes it is not necessary to connect the ROLL axis.

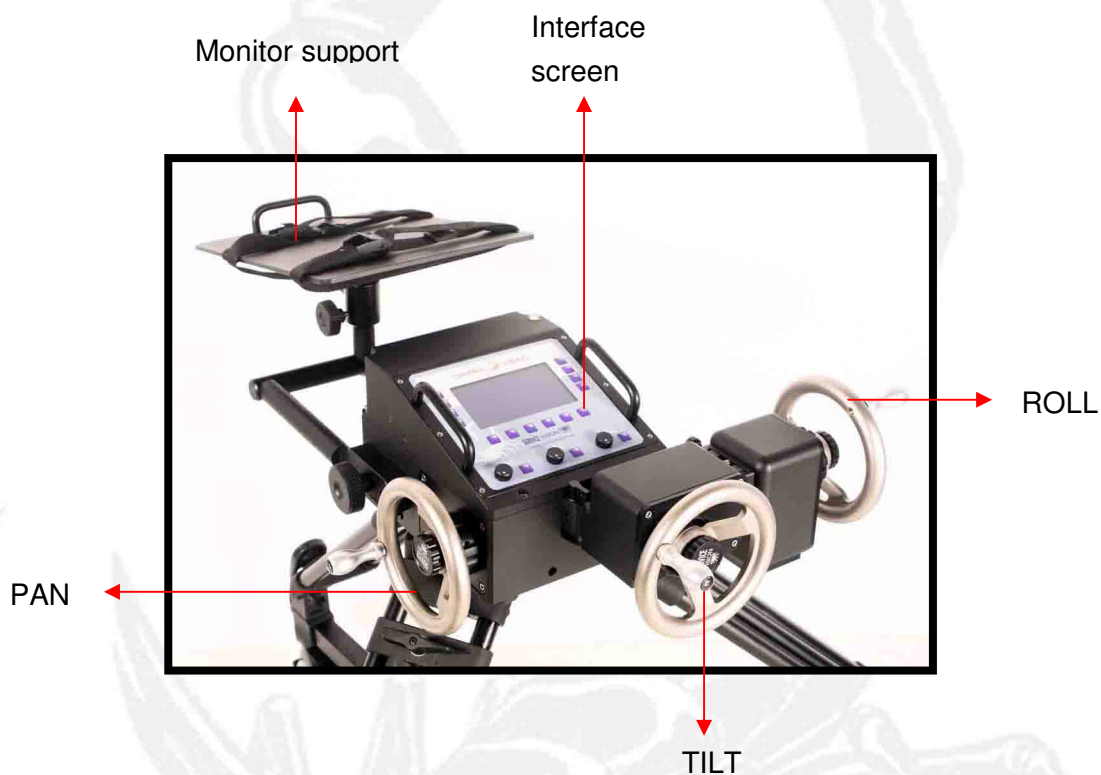

Transport case



Connections

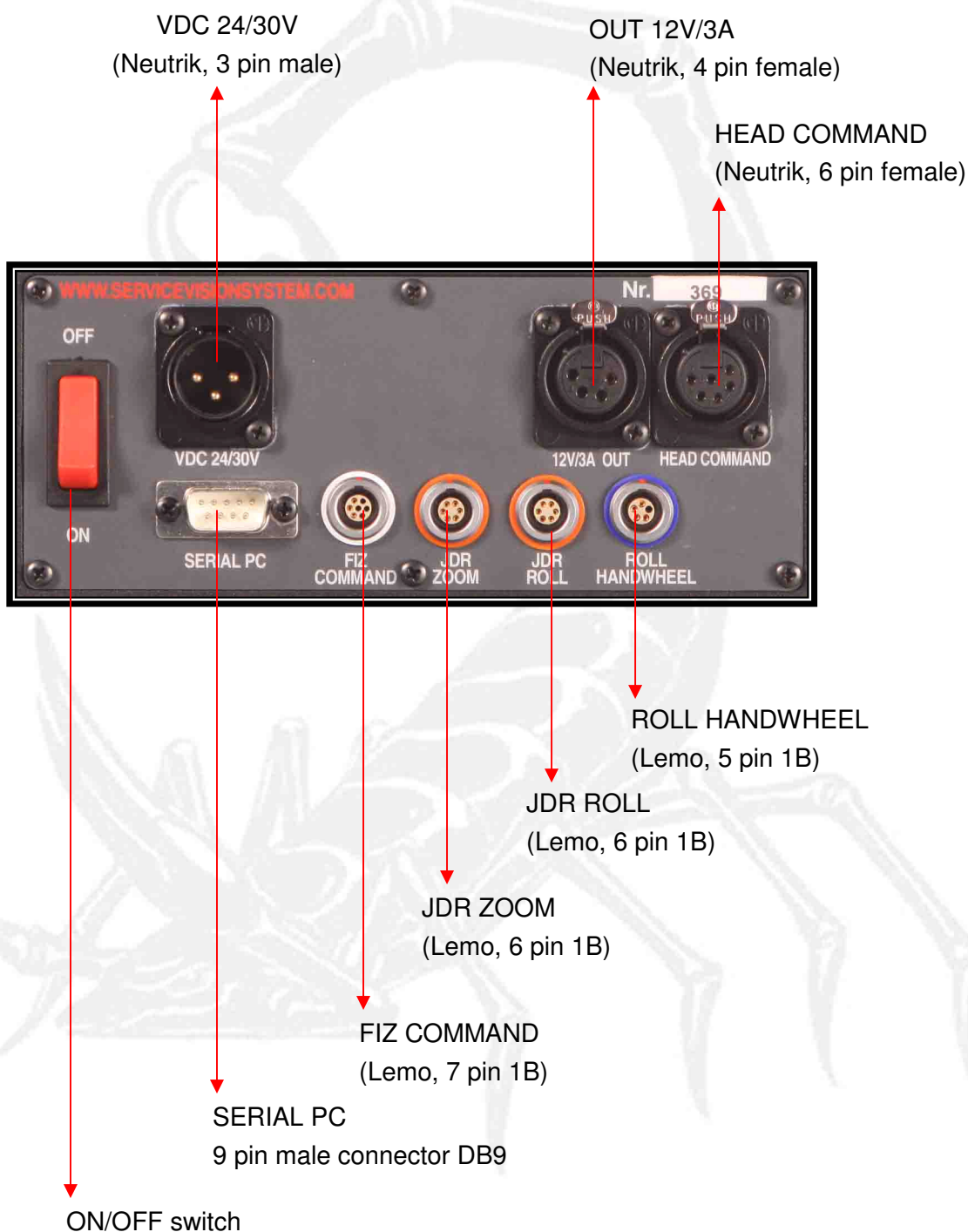

Handwheel mounting

First, the Handwheels body is fastened to a Mitchell mount tripod with the included fixation screw.



After that the handwheels are mounted onto the control desk. To mount the handwheels the central screw on the handwheel is fastened to an axis on the handwheels body.

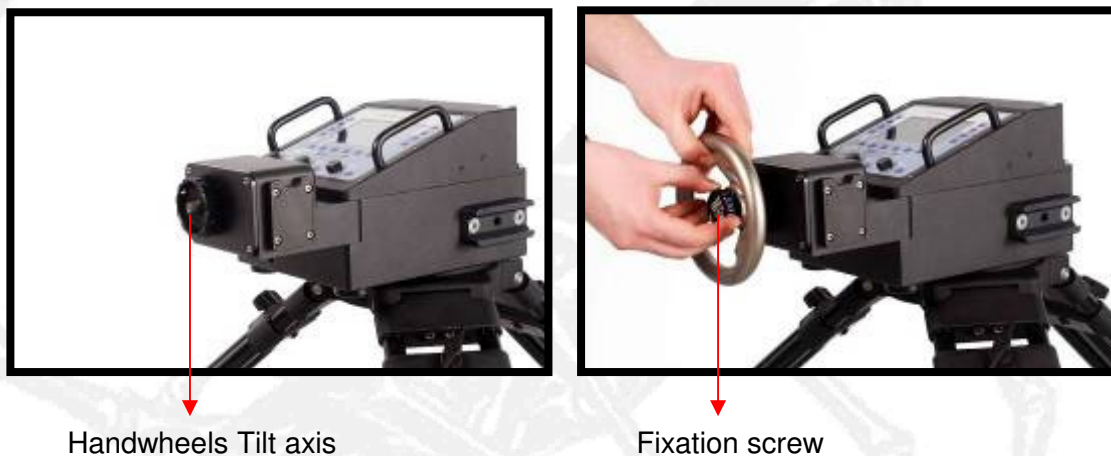

The tightness or fluidity of the handwheels can be adjusted via a fluid friction system. It is adjusted with the fluid regulator which is situated between each handwheel and the control desk.

Fluid regulator



In the case when the ROLL axis is used the third handwheel will have to be mounted. Before mounting the actual handwheel, the box with a slide groove (held with a fixation screw) has to be mounted to the control desk body and then the handwheel will be fastened to the box.

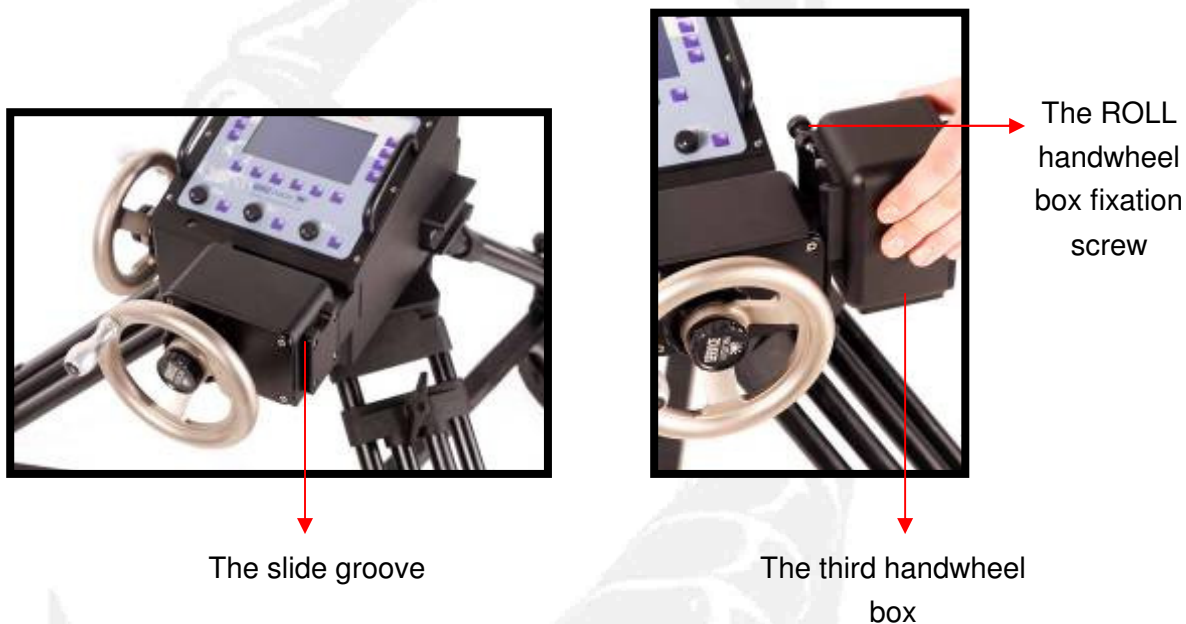

Lastly, the third axis box is connected to the ROLL HANDWHEEL connector.

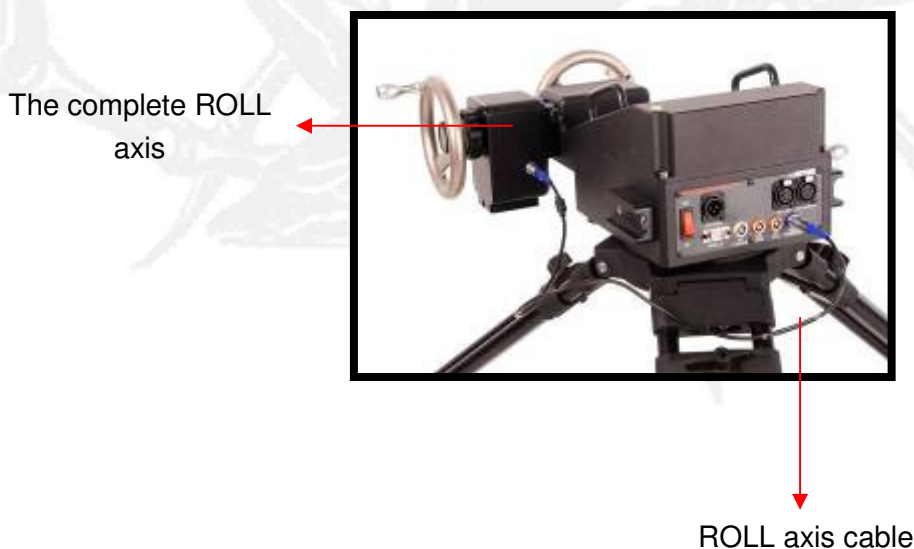

Monitor support

To be able to mount the monitor support the “U” shaped bracket must be mounted onto the control desk. The bracket is mounted onto the body via the two slip-in supports and fastened with two fixation screws.

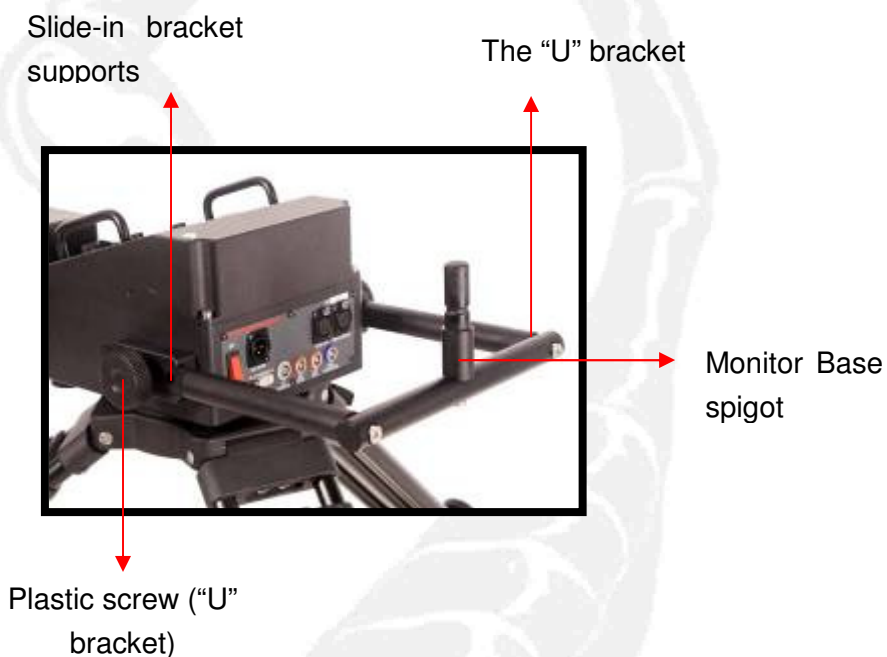

Once the “U” bracket has been fixed into place the monitor base can be mounted and fastened onto the monitor base spigot with the fixation screw.

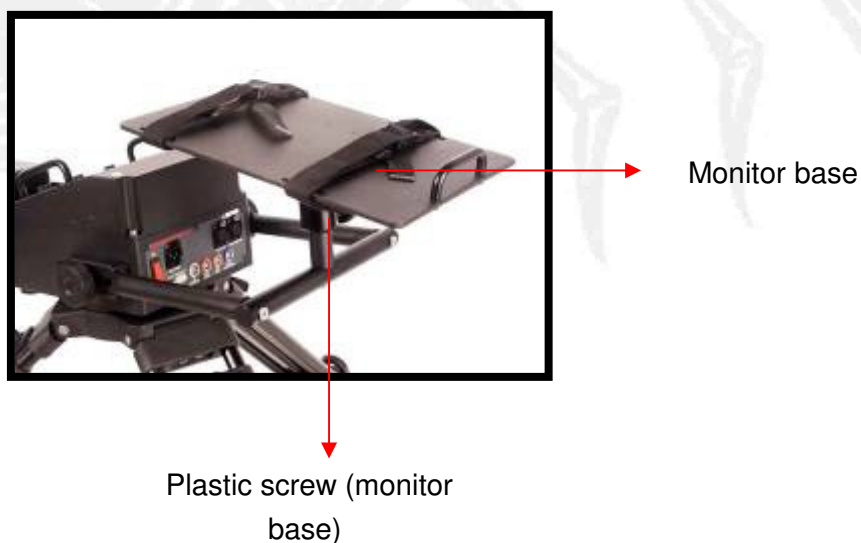

5.5.- Pan bar (JDR)

This control is based on the idea of moving the camera via two arms which are joined by an axis. There is a control on each arm which allows for different camera control functions.



Transport case



Connections

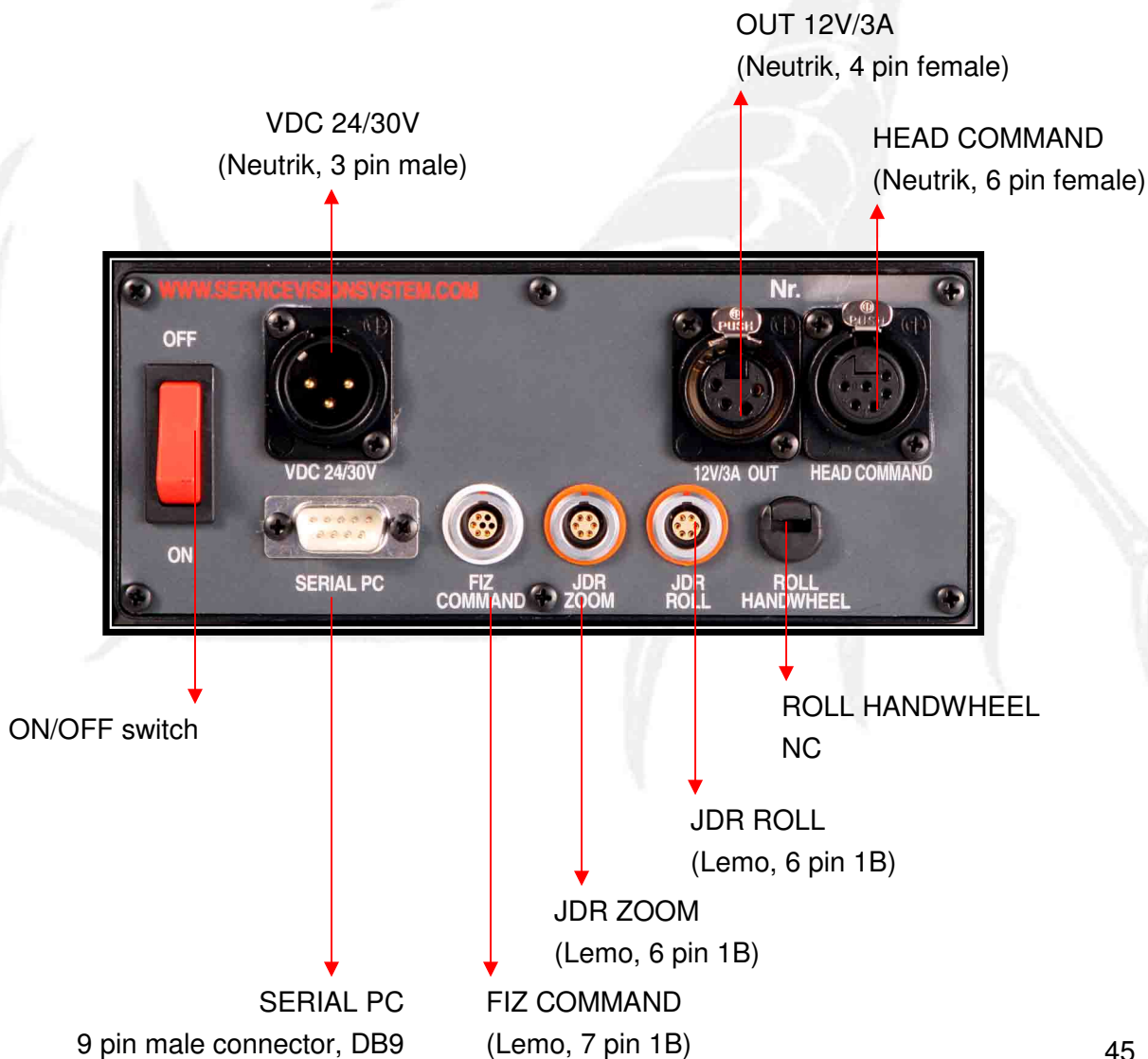

Mounting the control desk

As with the Handwheels the body will have to be mounted to a tripod with a Mitchell mount. A riser is mounted on the tripod to avoid bumping the arms against it.

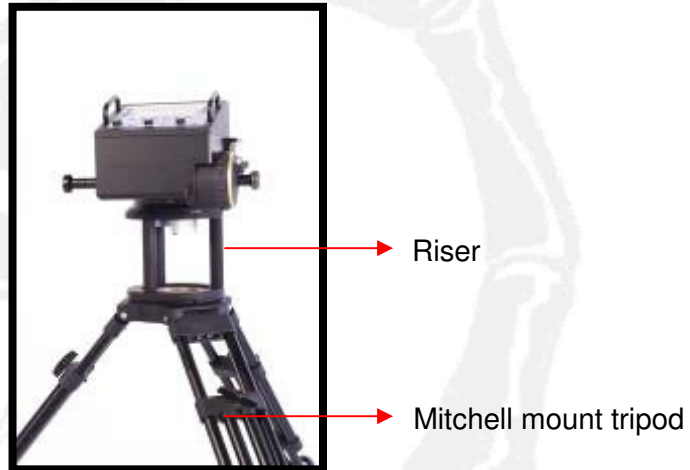

Mounting and connecting the controls

First the arms are mounted, with the longer arm on the right hand side (the side on which the fluid adjustments are found). They are attached and fastened with wing nuts onto the axis on the control desk as shown in the image below.

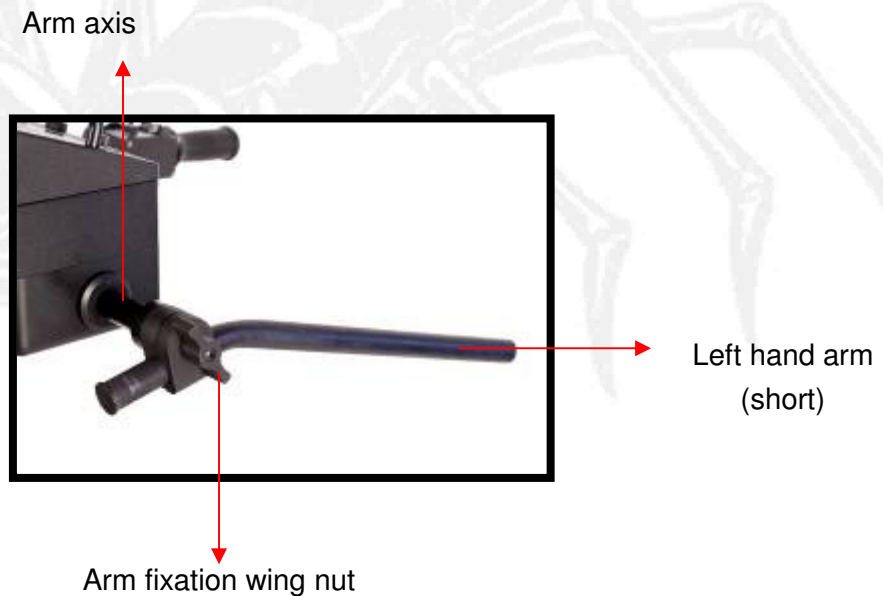

Once both the arms have been mounted the controls can then follow. To mount the controls correctly the two wing nuts must be on the inside of the controls (facing each other).



Now, all that is left is to connect the controls to their corresponding connectors. The right hand control will go to the JDR ZOOM connector and the left hand one will go to the JDR ROLL connector.



Mounting the counter weight

To be able to move the arms as comfortably as possible they have to be counter weighted. It is **VERY IMPORTANT** that they are completely balanced as to not have unwanted movement with the head and therefore the camera.

To balance the arms the safety screw at the end of the long arm is removed.



Safety screw

Once the safety screw has been removed the counter weight is put onto the arm at the approximate equilibrium point. By turning the black lock-off on the counter weight it is locked in place. Once it has been tightened the balance is checked and if it is not correct the counter weight is adjusted until the perfect balance is achieved.



Lock-off

Now that the balance is correct the safety screw that was removed in the first step is replaced on the arm. If, for whatever reason, the counter weight had to come loose this safety would stop it from falling off.



Mounting the monitor support

To mount the monitor support the same steps as with the Handwheels have to be followed. First the “U” shaped bracket is mounted into the slide-in supports on the control desk. The plastic screws are used to hold it in place. Then the monitor base is mounted on the spigot on the “U” bracket. The base is then fastened with the plastic screw on the shaft.

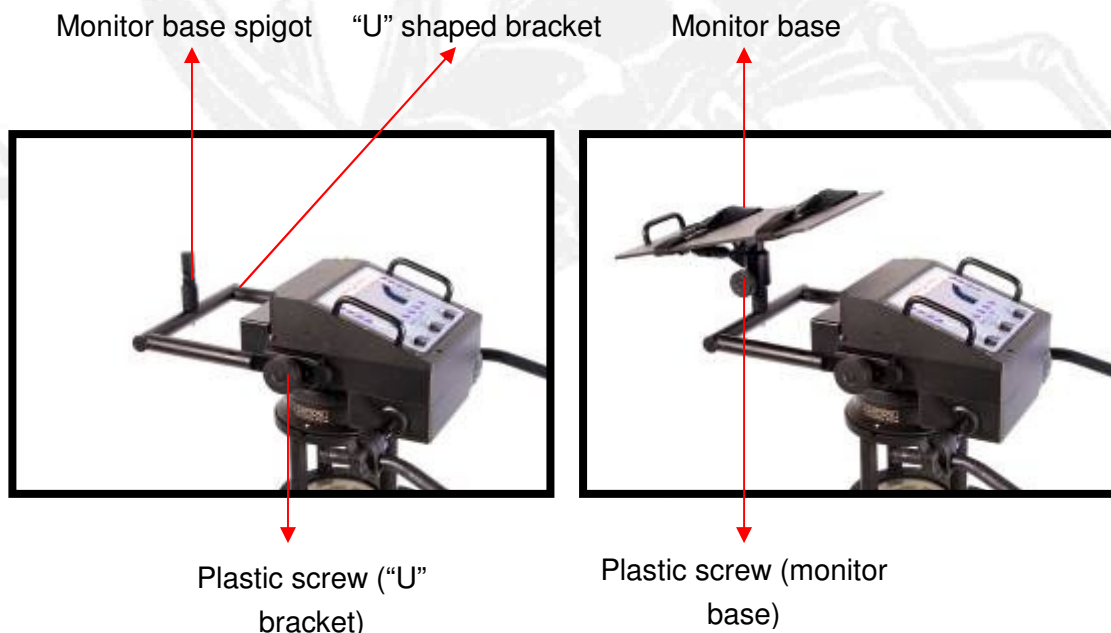

The fluid systems

The fluid system is based on a continuous fluid system which helps to obtain a smooth, constant and controlled movement. It has two fluidity control rings, one for the PAN and one for TILT. These control the counter force of the fluid. Each axis can be locked off with its corresponding brake.

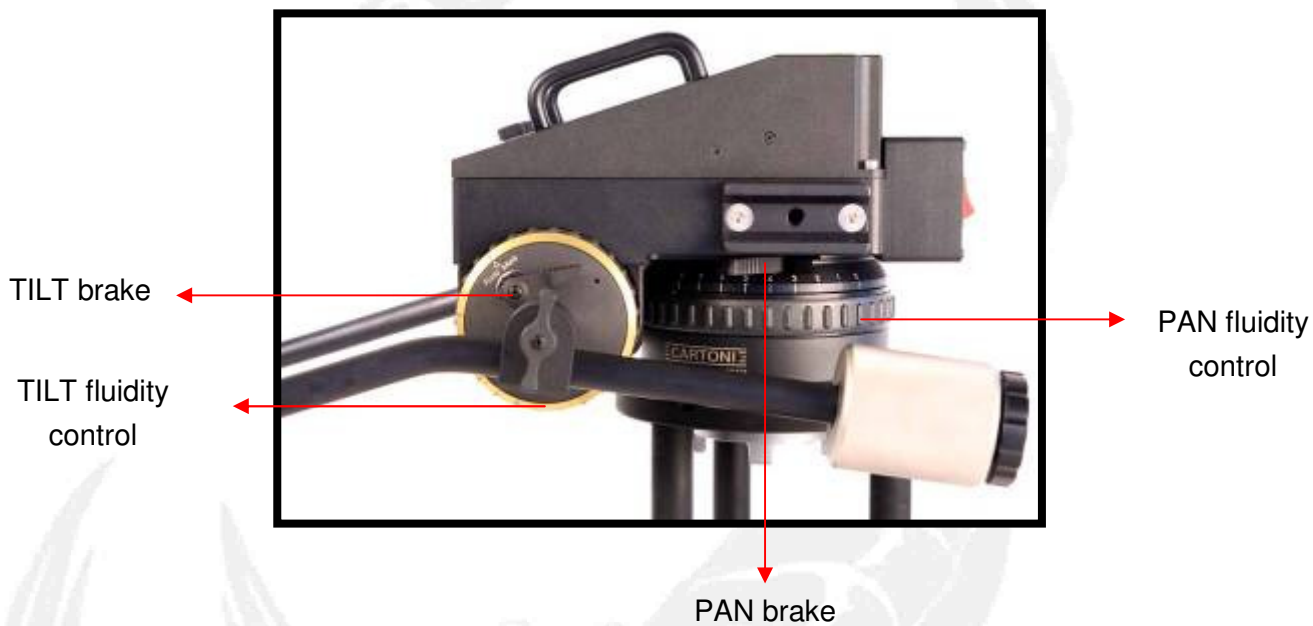

5.6.- Handheld

This control desk has two controls mounted on either side of it. The features of this control are the small size and its ease to move around.

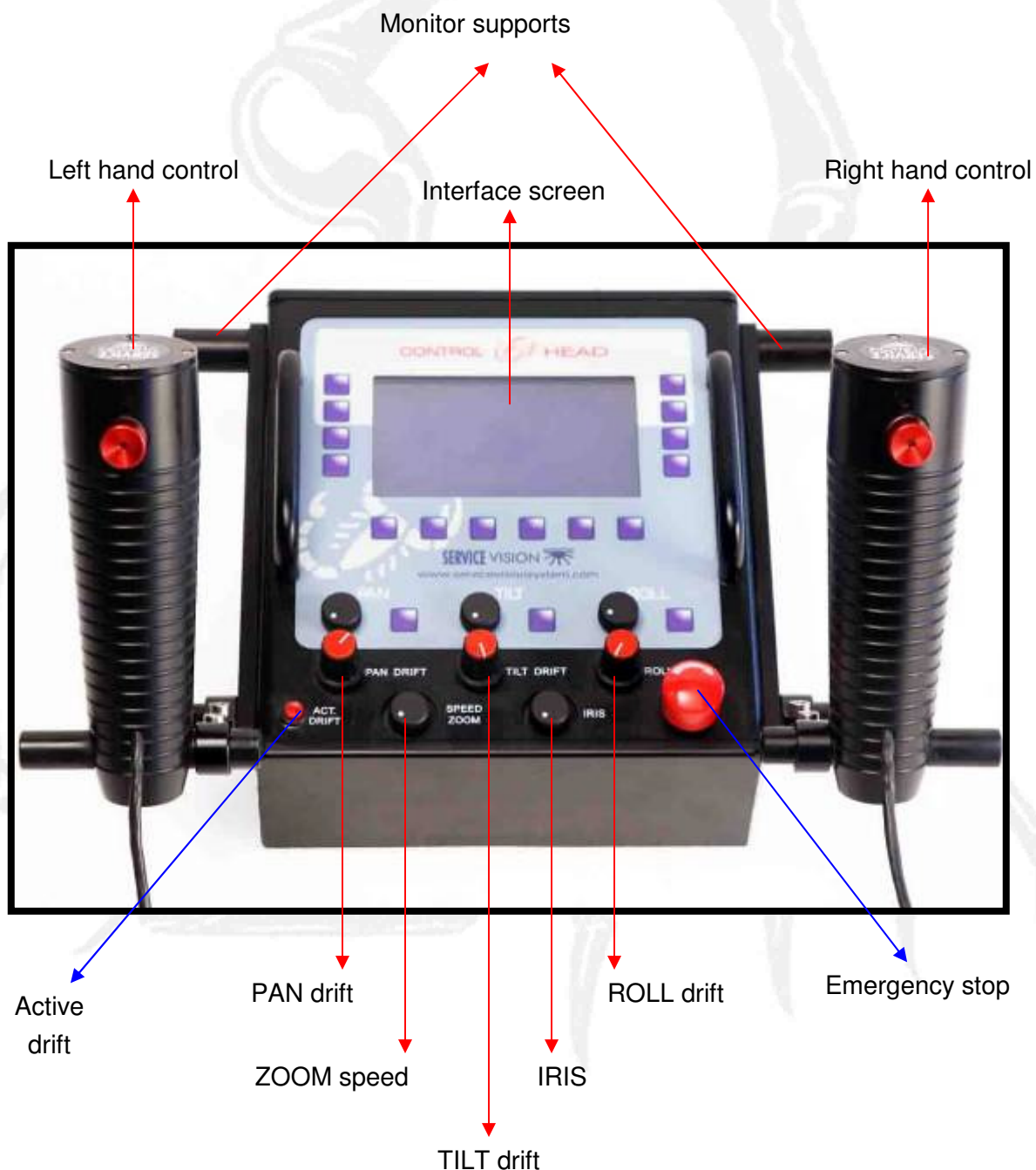

Transport case

This case has been made with a space for the monitor.

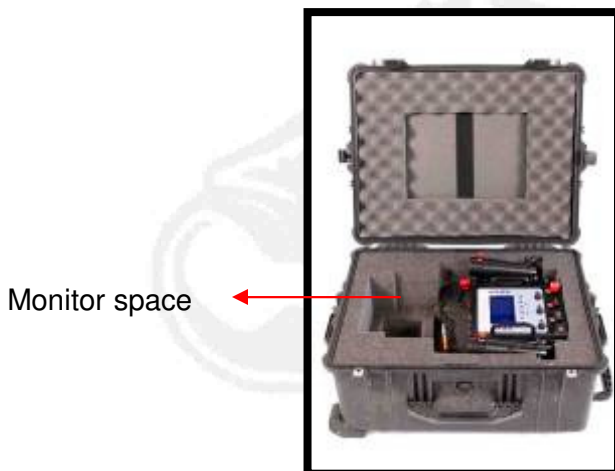

Connectors

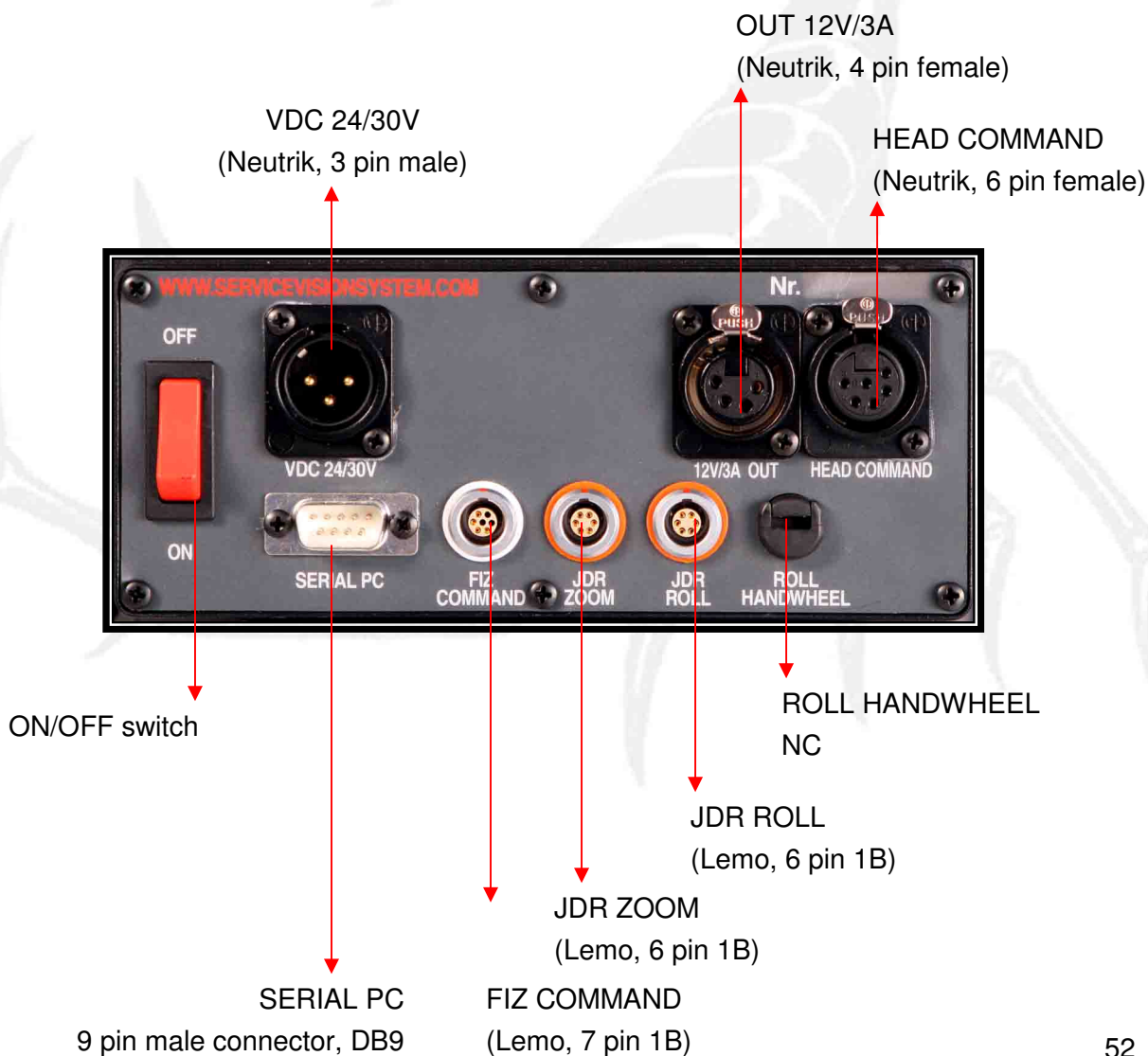

The control desk

Apart from the common interface screen which all the controls have, this control has some other features.

When using a stabilized head each axis's drift can be corrected. To do this the "drift activate" button is pressed and the potentiometer corresponding to the drifting axis is turned.

There are also two more potentiometers: one for the ZOOM speed and another for the IRIS.

This control also has an Emergency stop button. It is used if the system is not functioning correctly.

Control descriptions

The two controls are different. The one has a Joystick for the PAN and TILT on top and another for the ROLL underneath. The other has the Zoom control Joystick on top and a FOCUS control potentiometer below.

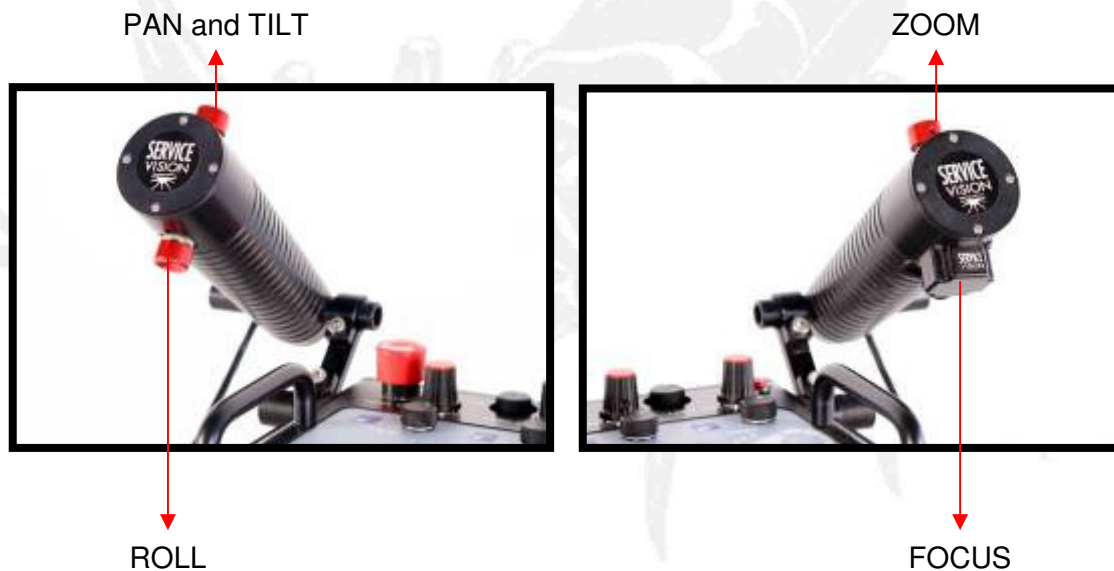

Mounting the controls

To be able to mount the controls the brackets that come with the control desk have to be mounted on both sides of the control desk (as seen below). Once the brackets have been mounted and the bottom screws have been tightened the control position can be adjusted with the top screw.

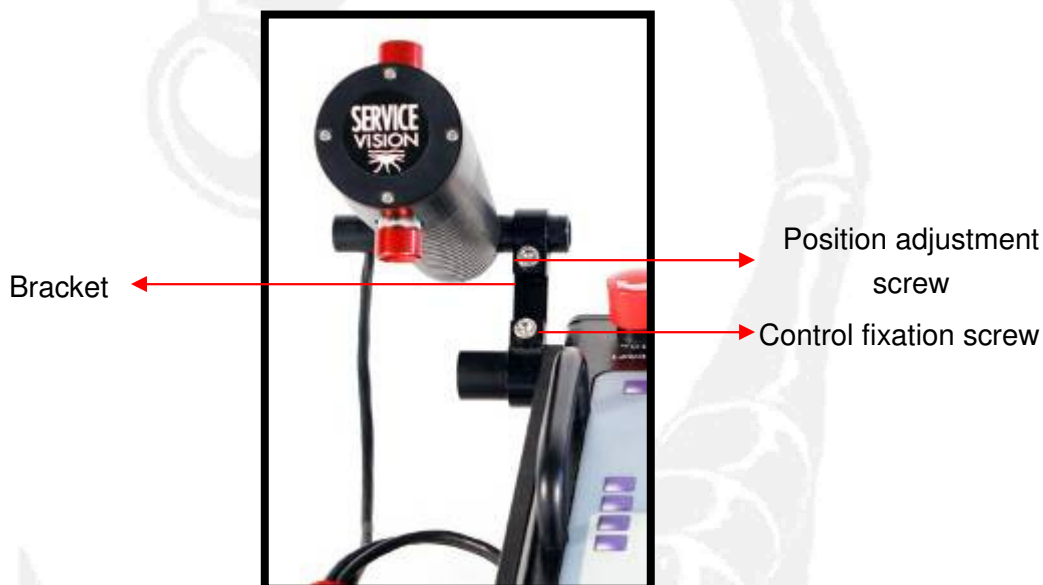

Once mounted the only thing left to do is to connect them. The control that is responsible for the head's movement will connect to the JDR ZOOM connector and the control responsible for the lens control will connect to the JDR connector.



6.- Set up

6.1 Mounting the head

The Mini Scorpio Head, whether in two or three axis, always comes mounted in its travel case.

The head in two axis:



The head in three axis:



This head has a Mitchell Mount for mounting it to its support.

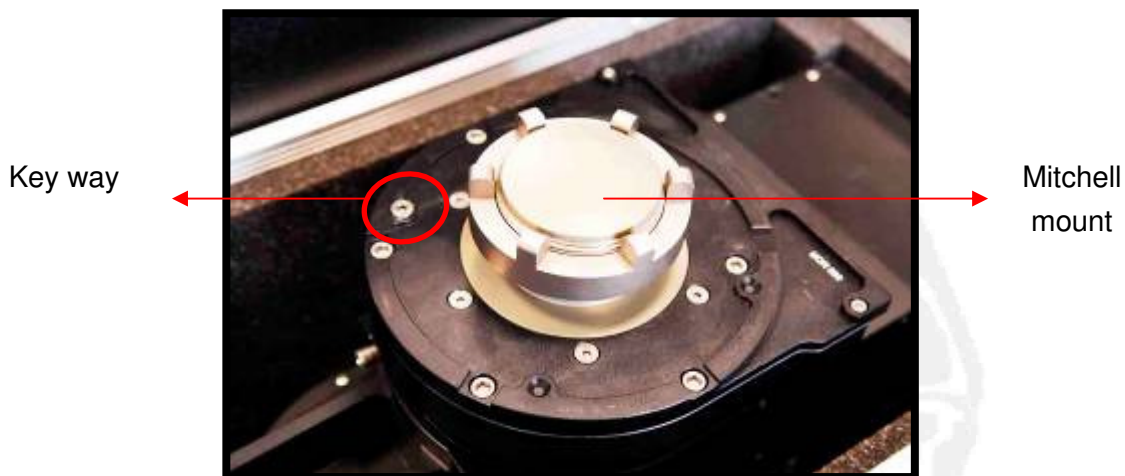

The head must be well tightened and the key way (shown in the photo) must be correctly slotted into its position on the support.

If the head is in the two axis configuration the camera can now be mounted.

If the head is in the three axis configuration we have to mount the extension and tensioning rods (see section “2.3.1.- Camera platform mount”)

6.2 Mounting the camera

Whether the head is in the two or three axis configuration the camera is mounted on the camera platform via two screws that are part of it.

In the case where the motor platform is used the screws will be longer as to sandwich it between the camera platform on the head and the camera.

Motor platform



Long screw
(33mm)



Short screw
(20mm)

Once the camera is fixed to the camera platform it then has to be balanced.

For the head's motors to work correctly it is very important that the balance is as close to perfect as is possible.

Whether in two or three axis configuration the balancing process is the same and starts with balancing the TILT axis.

The balancing is done by putting the camera in the horizontal position. While moving the camera up and down and checking the balance (it is balanced when it stops moving with its own inertia) the camera is slid back or forth on its slid plate until equilibrium is found.



In the two axis case the camera must be moved directly on the camera platform or its slide plate (if it has).



To balance the PAN the camera is put in the vertical position and its balance is adjusted on the “L”s vertical rods.



In the three axis case the camera can also be moved on the actual camera support platform rods.



Once the horizontal balance has been reached the camera is put in the vertical position (parallel to the TILT axis) and it is balanced moving it from one side to the other. If we see that the balance is not correct it is corrected by moving the camera on the “L”s vertical rods.



After that we re-check the horizontal balance to make sure that the head is balanced throughout the full 360° rotation.

6.3 Cable connections

6.3.1 Power

The Mini Scorpio Head can be powered by batteries or by a power supply.

The permissible voltage range is between 26 and 34V. The maximum current consumption is 8A.

The power cables have a maximum length of 14 meters. If the length needs to be increased the cable diameter must also be increased accordingly.

The Head Power line gives power to all the axes and the Scorpio Focus motor driver box.

The head also has another power line, Camera Power, which powers the internal power supply for the camera. This line has the same voltage range as the Head Power line.



Internal power for
the head

6.3.2. Communication

The communication between the head and the control is via a series RS485 channel. This communication link can be by radio or cable.

When using the cable mode a twisted pair cable which can be up to 1Km is used.

When using the radio mode the Scorpio Radio system which works on a frequency range between 2,4 and 2,5 Ghz is used.



Head control desk

Emitter

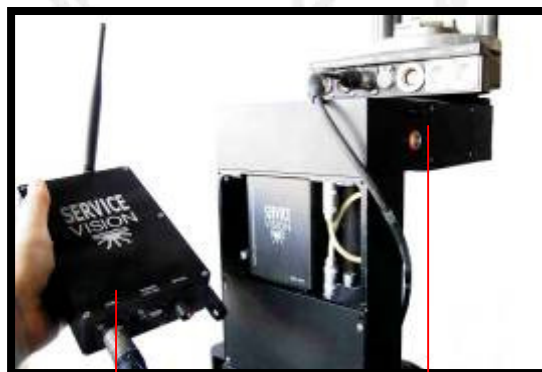

Receiver

Mini Scorpio Head

6.3.3 Video signal

If the camera that we use is Pal or Ntsc the Video 1 or Video 2 connectors will be used to transmit the video signal from the camera via the head to the monitor.

If the camera is HD we use the Triax connector with a Triax to BNC convertor cable.

If the camera is Triax we use the Triax connector with the corresponding Triax adaptor cable.

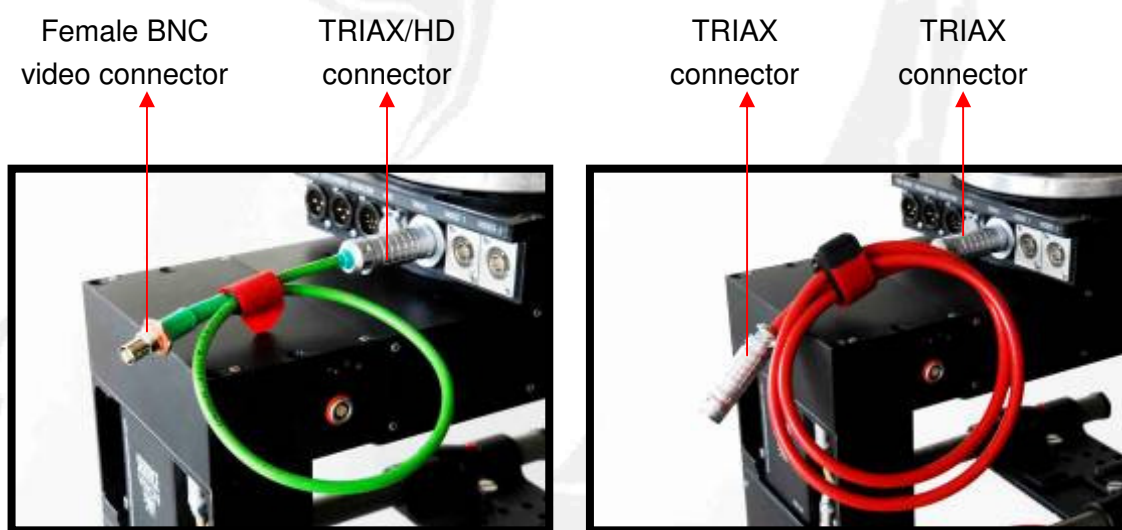

HD connection

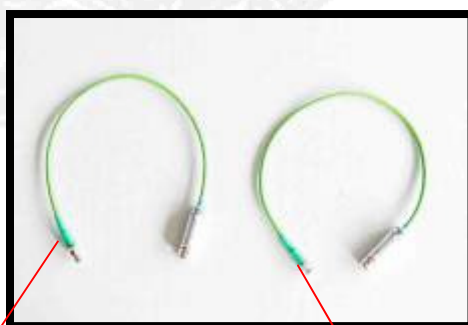

PAN axis connector for sending HD signal to monitor (female BNC)

ROLL axis connector for receiving HD signal from the camera (male BNC)

TRIAx connection types

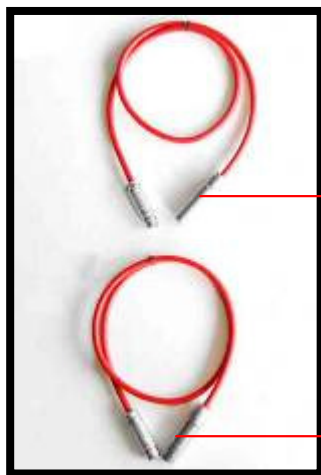

→ FISHER connector from control (female)
Connector ref. : FRZ.T7.5FT.MC86C

→ FISHER connector from camera (male)
Connector ref. : FAZ.T7.5FT.CC86C

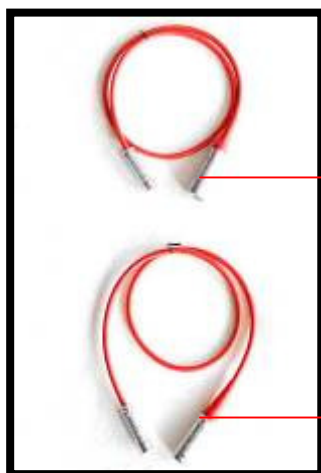

→ BIG LEMO connector from control (female)
Connector ref. PCA.4E.675.CTLC85Z – GMA.4B.080.DR

→ BIG LEMO connector from camera (male)
Connector ref. FFA.4E.675.CTAC85Z – GMA.4B.080.DR

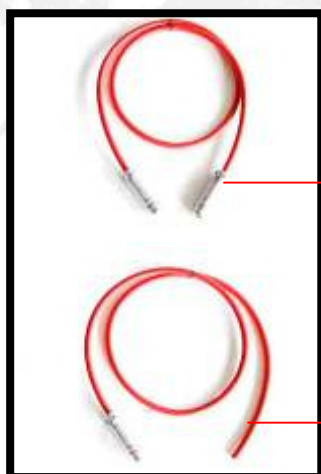

→ LEMO connector (Female)
Connector ref. : FFA.3T.675.CTAY92

→ Open cable for any other connection.