

Hybrid™ IV Camera Dolly

USER GUIDE

Operational Instructions & Specifications



CHAPMAN/
LEONARD
STUDIO EQUIPMENT, INC.

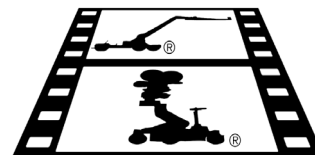

CHAPMAN/ LEONARD

STUDIO EQUIPMENT, INC.

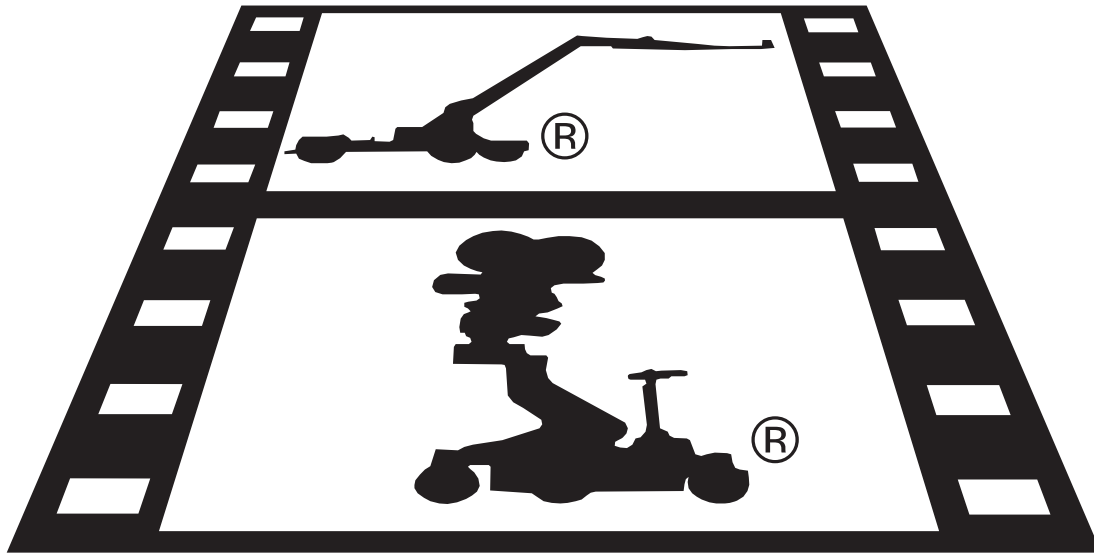

It is Chapman/Leonard's goal to provide the best camera support equipment with exceptional Customer Service. For any questions regarding this User Guide, please contact Customer Service at **888-883-6559** or **818-764-6726**.

Chapman / Leonard Certified Locations:

MAIN OFFICE

12950 Raymer Street,
North Hollywood, CA 91605

www.chapman-leonard.com

Toll Free: 888-883-6559

818-764-6726

Fax: 818-764-6730 *Rentals*

818-764-4347 *Leasing*

818-764-9391 *Accounting*

Florida

9460 Delegates Drive
Orlando, Florida 32837

Toll Free: 888-337-8243

407-851-3456

Fax: 407-855-1653

UK and Europe

Chapman Leonard Studio
Equipment, Ltd.
Unit 2

North Orbital Commercial Park
Napsbury Lane, St. Albans, Herts
England AL1 1XB

www.chapmanleonard.com

+44 1 727 838424

Fax: +44 1 727 852241

Louisiana

668 Distributors Row Suite E
Elmwood Business Park
New Orleans, LA 70123

Toll Free: 888-758-4826

504-731-6050

Fax: 504-731-6051

Georgia

120 Parkwest Drive #D
McDonough, GA 30253

Toll Free: 888-758-4826

Fax: 678-583-1858

Texas

1901 E. 51st Street
Austin, Texas 78723

Toll Free: 888-758-4826

512-473-0084

Fax: 512-473-0042

New York

38-75 11th Street
Long Island City, NY 11101

Toll Free: 888-758-4826

Fax: 718-389-1899

Ohio

15919 Industrial Parkway
Cleveland, OH 44135

Toll Free: 888-758-4826

216-241-4800

Fax: 216-241-4805

New Mexico

5650 University Blvd. SE
Albuquerque, NM 87106

Toll Free: 888-758-4826

Fax: 505-227-2578

The Operator should be Qualified. For Assistance Please call our 24 hour Customer Service at 1-888-883-6559.

© 2001 No part of this manual may be reproduced or electronically transmitted without the written permission of Chapman/Leonard Studio Equipment, Inc.

CONTENTS

1	Specifications
2	Line Drawings with Dimensions
3	Geometry Lever
4	Arm Markers
5	Shifting/Steering Modes
6	Steering Choices
7	Steering Column Extension Adapter
8	Feathering Levers
9	Fast Mode
10	Detent Bypass
10	Float Mode
12	Charging the Dolly - Electronics
13	Control Valve & Gauge
13	Brakes
14	Leveling Head Choices
15	Indexed GQ Leveling Head with Cam
16	Attaching Boards in Lower Walk-Around Mode
17	Attaching the Side Boards
18	Attaching the Front Board
19	Upper and Lower Board Setup Modes
20	Side Board Configurations
21	Storing the Accessories
22	Quick Release Wheel Locks
23	Quick Jack
24	Cleaning the Hybrid IV
24	Accessories
25	Packing the Dolly for Transport
26	Shipping and Rental Return

Hybrid™ IV Specifications

Minimum Camera Mount Height	19 in. / 48.3 cm
Maximum Camera Mount Height	62 in. / 1.57 m
Vertical Boom Travel	43 in./1.09 m
Minimum Camera Mount Height (Low Plate Setup)	4 in. / 10.2 cm
Maximum Camera Mount Height (Low Plate Setup)	64 in. / 1.63 m
Maximum Load Capacity with Accumulator Charge @ 3100psi	700 lbs. / 317.5 kg
Maximum Capacity of GQ Head with Strut Attached to Head	350 lbs. / 158.8 kg 700 lbs. / 317.5 kg
Maximum Number of Lifts on a Single Charge	6 Lifts
Carrying Weight (without Wheels, Head and Steering Column)	395 lbs. / 179 kg

The Hybrid IV in Low Profile Mode with Attachments Removed for Shipping or Storage.

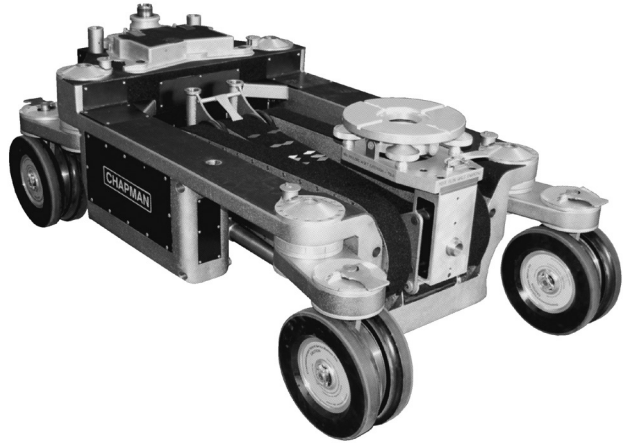

With the deck controls removed, there is no interference for achieving 360 degree pan shots.

The Hybrid IV is capable of three different steering modes:

1. **Conventional Mode:** Rear wheels pivot as the operator makes a tracking turn
2. **Crab Mode:** All wheels turn in unison, enabling the dolly to be moved in any direction while maintaining the orientation of the camera plane.
3. **Round Mode:** The dolly can turn while remaining in the same spot.

Steering modes can be selected by twisting the steering handles.

Control Pins can be set to limit which modes can be selected during critical moments, ensuring the operator can make transitions with confidence.

The **Universal Stop Valve** controls arm movement with smooth, feathered stops.

Adjustments to the Universal Stop Valve can be made without tools or the need to remove any covers or access plates. Feathering Levers for the Stop Valve are located below the Steering Controls, within the operators reach for ease of use.

The arm is a new design with greater rigidity, smoothness, speed and quietness of operation. Six full strokes of the arm are possible with a single charge.

The Hybrid IV has a **new Valve Control** providing Detent Adjustment and a new "**Float**" mode. This feature provides instant direction change for the Arm.

A **new tire design** has dramatically reduced friction for smoother rolling shots. Tires can be matched to various track configurations.

The **Side Board System** provides complete walk-around-capability on the dolly in both high and low level setups.

The Hybrid IV has a built-in **heat control system** in the hydraulic system to maintain a minimum hydraulic oil temperature of 70°F. This maintains optimum performance in even the coldest environment.

HYBRID™ IV

Camera Dolly

Stripped Down Carrying Weight = 395 lbs. (180 kg)
 Maximum Payload with Strut Attached = 700 lbs. (317.5 kg)

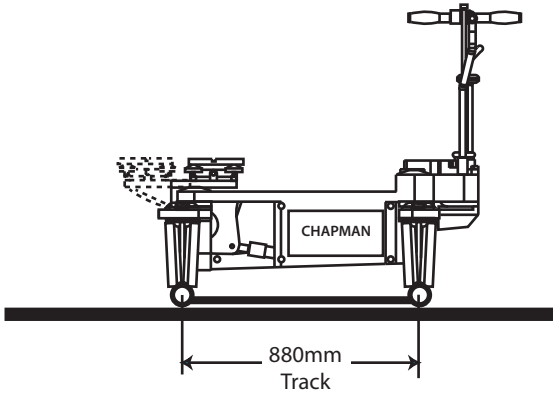

880mm Track Configuration
 (Legs are set at 80 degrees)

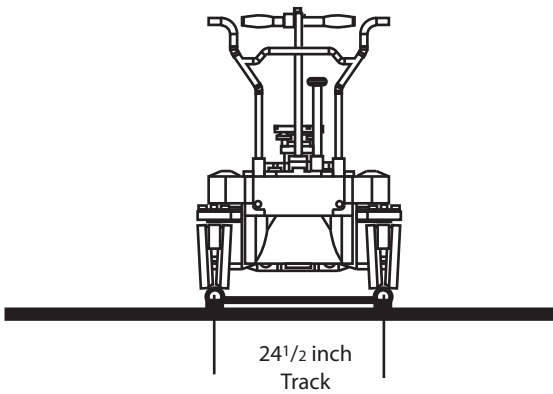

Standard Track Configuration
 (Legs are set at 12 degrees)

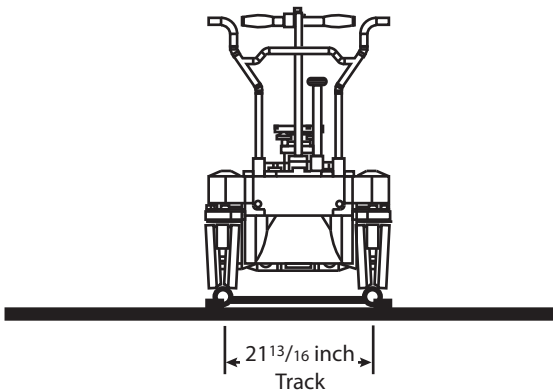

Compact & Narrow Track Configuration
 (Legs are set at 0 degrees)

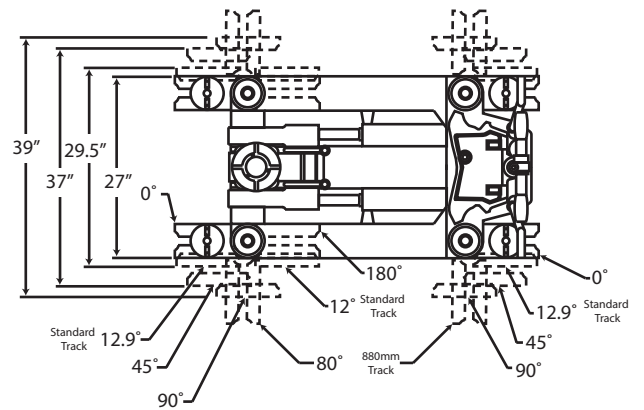
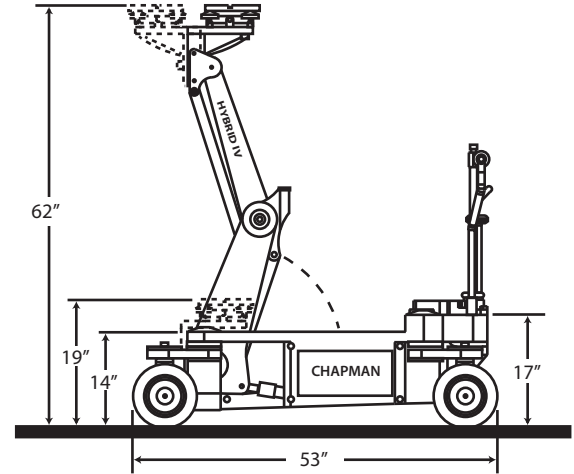

Top View of Leg Configurations

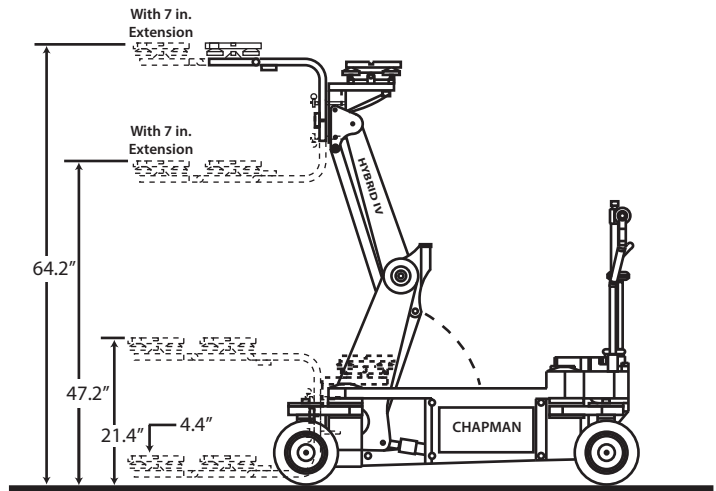

90° Low Profile Extension

Hybrid™ IV Geometry Lever

The Geometry Lever changes the angles of wheel orientations to each other when special configurations are chosen. This allows positive tracking of the wheels in all situations.

The lever has three positions. Before the Geometry Lever is moved, the transmission must first be shifted into the Crab Mode. When the front wheels are in the 0° or 12° positions, the Geometry Lever must be moved to the left toward the center line of the Dolly (Inboard). When the front wheels are at any other position, the Geometry Lever must be moved to the right (Outboard).

A sticker is mounted near the Geometry Lever as a reminder.

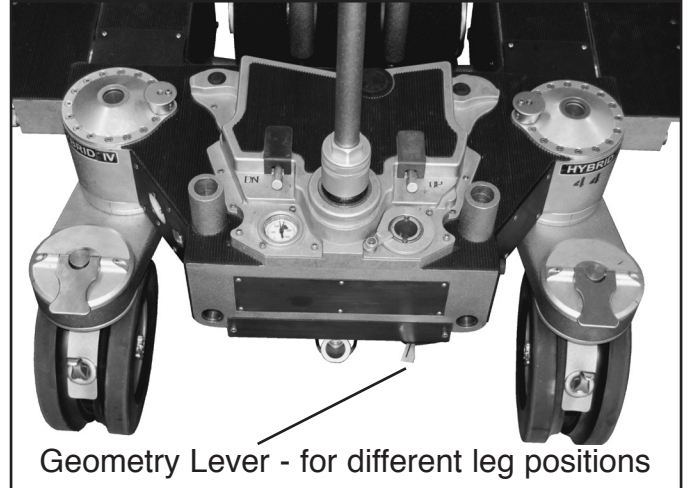

Geometry Lever - for different leg positions

Setup	Leg Positions	Geometry Lever	Comments
Standard EURO Track	80° on All Legs	Lever All Other	880mm Track-Dolly Sideways
Standard Track	12.9° on All Legs	Lever 12°	24 ¹ / ₂ " Track
Narrow Profile	0° on All Legs	Lever 0°	Through Doorways
Compact Profile	180° Front Legs (Standard Tires)	Lever All Other	Smallest Footprint
	0° Rear Legs (Standard Tires)		
	168° Front Legs (Pneumatic Tires)		Fits on Standard 24 ¹ / ₂ " Track
	12° Rear Legs (Pneumatic Tires)		Fits on Standard 24 ¹ / ₂ " Track
Wall Hugger	90° Right Legs (Away from Wall)	Lever All Other	Asymmetrical
	0° or 180° Left Legs (Next to Wall)		Crab & Round Mode Only (Leg Orientations can be reversed)

The Asymmetrical profile of the Wall Hugger Configuration allows camera placement close to a wall or structure while maintaining a more stable platform for the Operator.

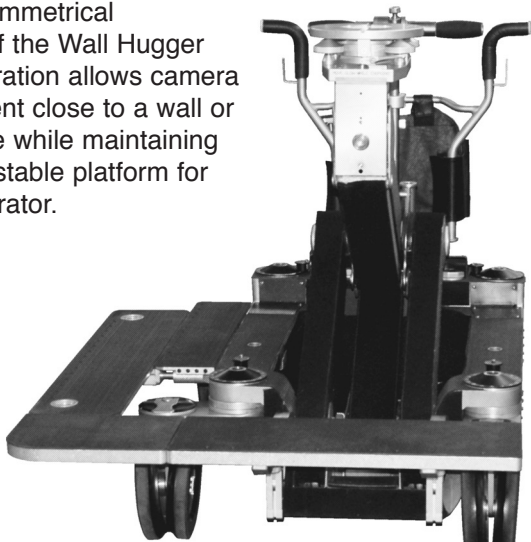

Wall Hugger Configuration

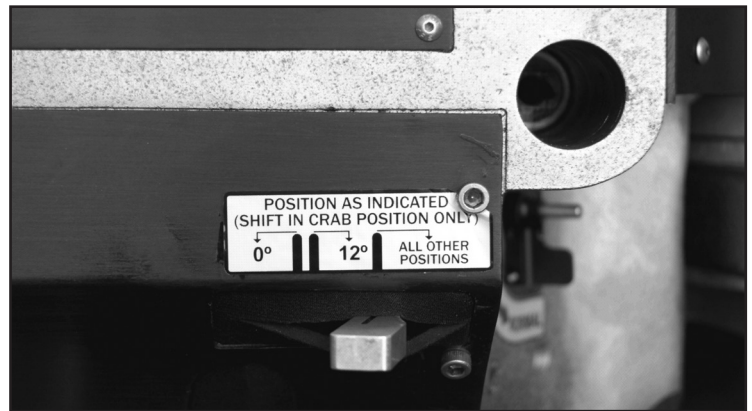

Steering must be in Crab Mode to change between setups
Set legs to desired configuration
Shift the Geometry Lever to match the leg configuration.

Tip: Use the QuickJack to help make quick leg changes

Hybrid™ IV Arm Markers

Colored Velcro Markers attach to the Arm (Upper and Lower). They can be repositioned to different locations on the Arm as a visual aid in repeating an Arm movement.

The Arm travels on a vertical line, eliminating focus problems on extreme close ups.

Precise, repetitive Stops are possible at all speeds.

An improved Stop Valve System allows even faster, smoother stops.

A variety of options are available to the Grip when using the Control Valve.

A Single or Double Detent can be set on the Hybrid IV. This is usually set at the Chapman facility. However, it is a simple adjustment that can be performed in the field by a qualified technician.

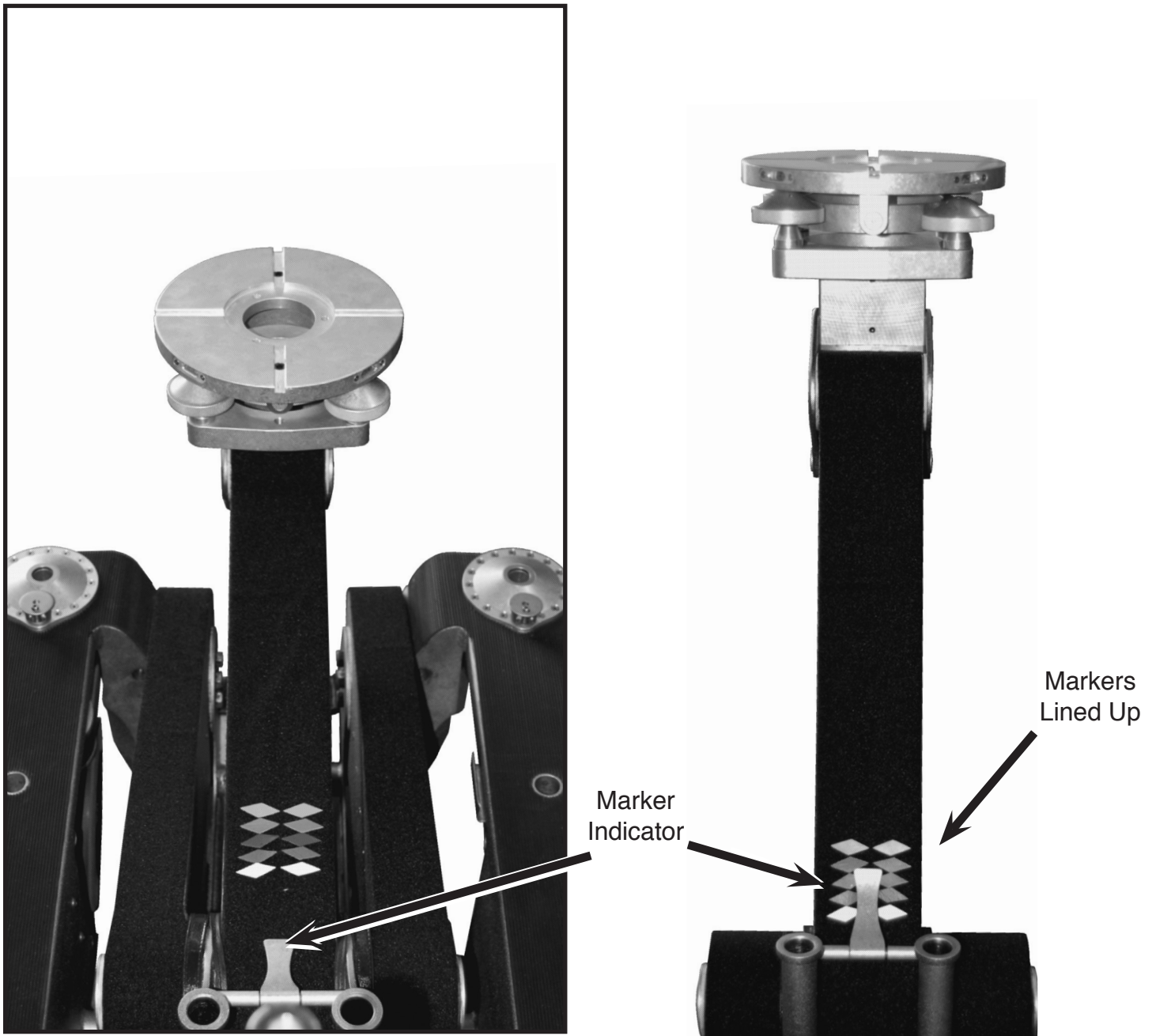

Hybrid™ IV Shifting/Steering Modes

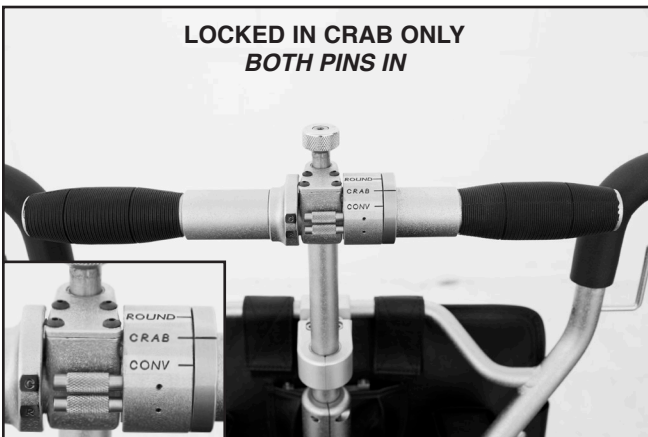
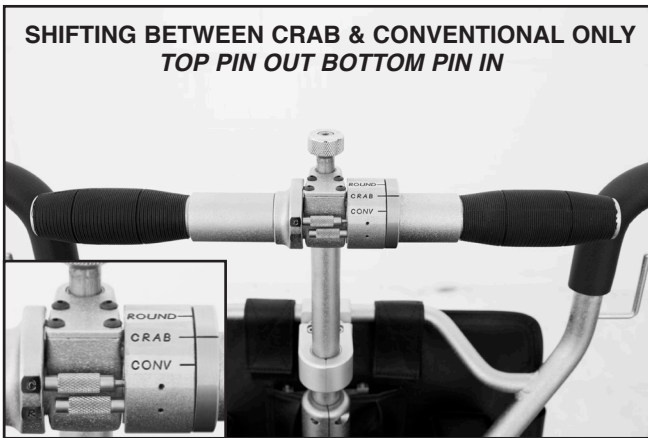

The Hybrid IV is capable of three different steering modes. In **Conventional** Mode the rear wheels pivot as the operator makes a tracking turn. In **Crab** Mode all wheels turn in unison enabling the dolly to be moved in any direction while maintaining the orientation of the camera plane. In **Round** Mode the Dolly can turn while remaining in the same spot. The operator can select any mode by twisting the Steering Handles. Control Pins can be set to limit which modes can be selected during critical moments, ensuring the operator can make transitions with confidence.

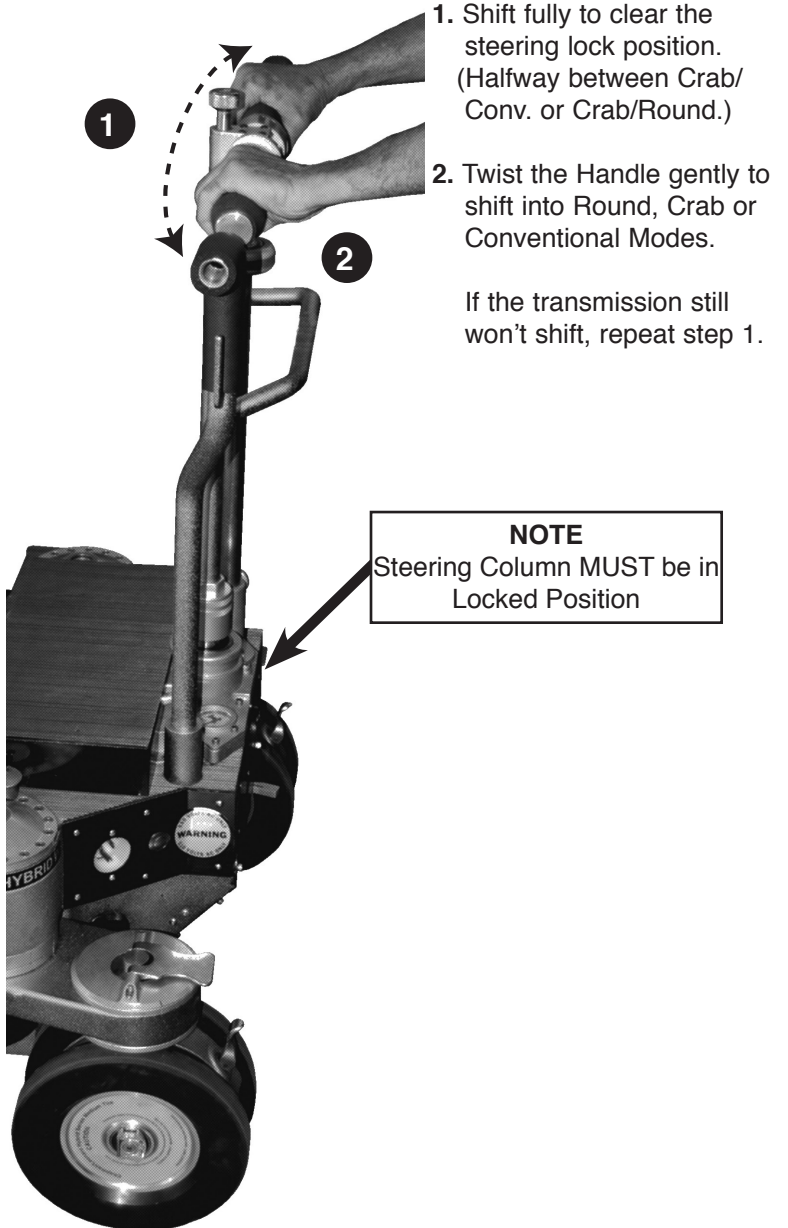

When attaching the Steering Column to the Dolly, the Lockdown Collar should be tightened by hand only. Never use pliers or channel locks on any part of the Dolly.

Hybrid™ IV Steering Modes

The Conventional Steering Mode is rear controlled steering. The Hybrid IV can be shifted smoothly into either Round or Crab Steering Modes during the course of a shot, even while moving. Steering Control Pins (see page 7) aid the Grip in making the desired transitions with confidence.

Minimum Turn Radius 31 inches

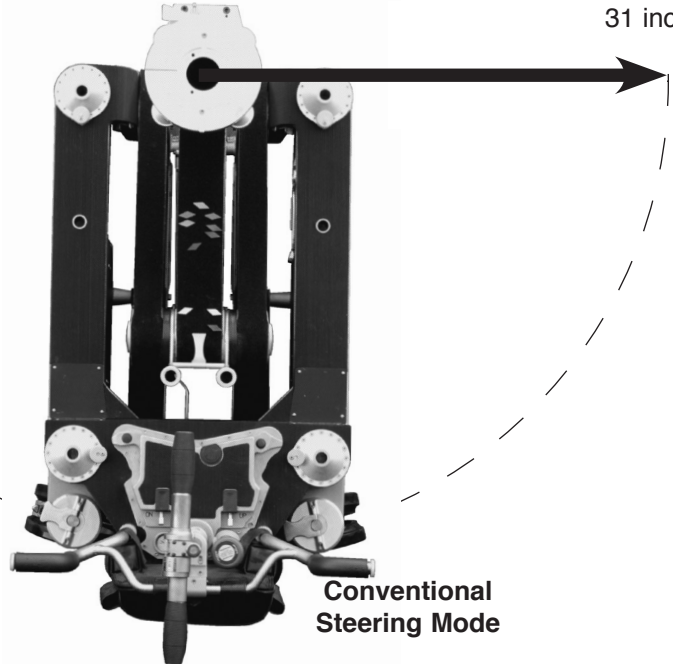

The Round Steering Mode is a new feature of the Hybrid IV. The Dolly can now be turned completely within its own space, making it an ideal choice for tight locations.

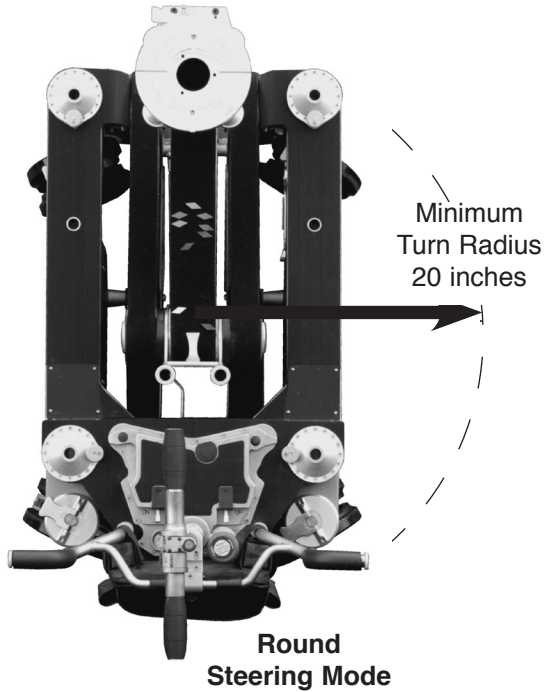

The Crab Steering Mode is the selection used most often by experienced Grips. It gives them more control moving the Dolly instantly in any direction. The camera lens maintains its orientation to the picture plane, ensuring a steady shot without unwanted panning.

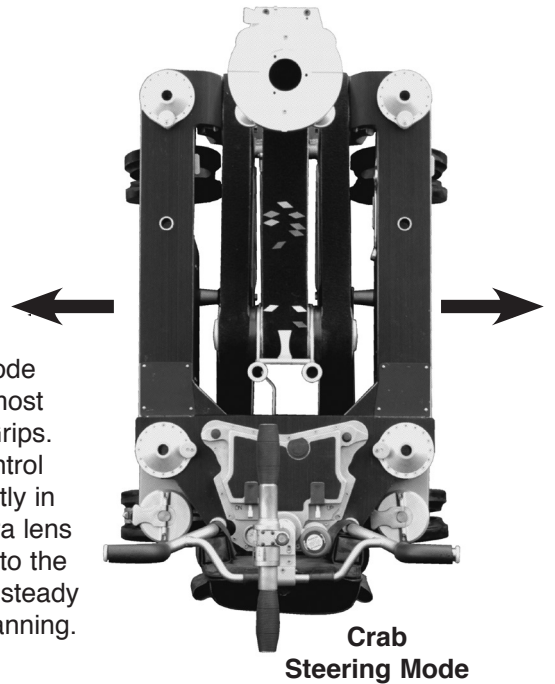

Hybrid™ IV Steering Column Extension Adapter Installation

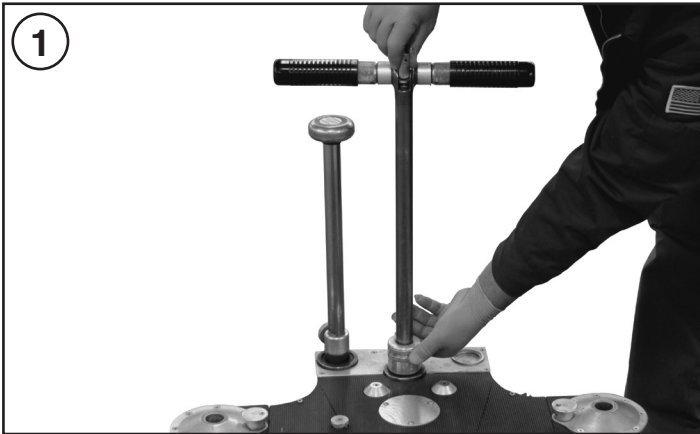

Every Chapman Dolly has the ability to accept a Steering Column Extension Adapter. Begin by removing the steering column. Turn the thumb screw at the top while holding the bottom collar until it feels loose. Then turn the bottom collar until it can be removed.

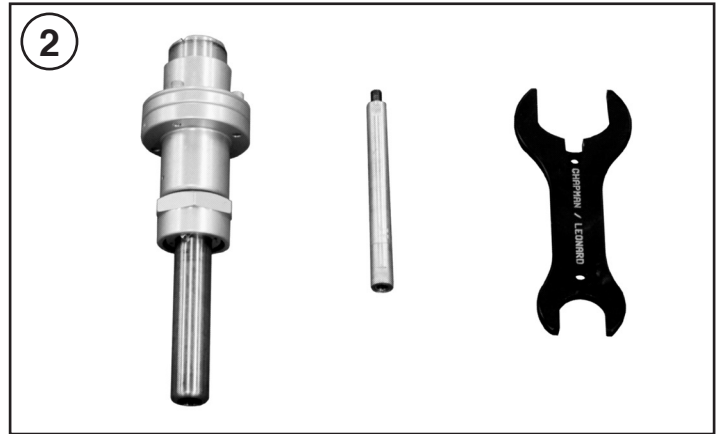

Each Steering Column Extension Adapter kit is specific to a dolly type. In this example, we will assemble the type used on the Hybrid Series of Dollies.



Attach the Extension Nut to the bottom end of the Steering Column.



Tighten the Extension Nut with the Extension Wrench.



Insert the Steering Column Extension into the Receiver on the dolly and tighten with the Extension wrench.

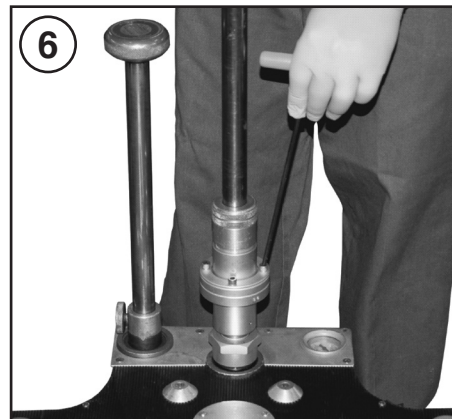

Make sure that the wheels are all oriented in the "Straight" position. Then align the Steering Handle in the "Straight" position. Tighten the Extension Adapter with an Allen Wrench.



Tighten the Steering Handle thumb screw and collar. Test the dolly by tracking in a straight line.

A Customer Service Representative can help you with ordering replacement parts or connect you with a Chapman Technician who can guide you through the assembly procedure.

Hybrid™ IV Feathering Levers

The **Universal Stop Valve** regulates the speed and smoothness of the Arm deceleration to a selected Stop. The Feathering Levers are located to either side of the Steering Handle. They are used for fine tuning the operation of the Universal Stop Valve. The Arm will move to the upper and lower Stops that the operator has designated, instead of the factory settings. This also ensures that the Arm does not “Bottom-Out” when lowered to the Chassis.

The **UP Feathering Lever** is located to the right (standing at the rear of the Dolly). Pushing the Lever in to engage, then moving the Lever Back (ratcheting) allows the Arm to travel further up (Maximum Arm Height). Moving the Lever Forward (ratcheting) limits the Arm travel height.

The **DOWN Feathering Lever** is located to the left. Pushing the Lever in to engage, then moving the Lever Back (ratcheting) limits the Arm movements lowest position. Moving the Lever Forward (ratcheting) allows the Arm to travel to a lower position (Minimum Camera Height).

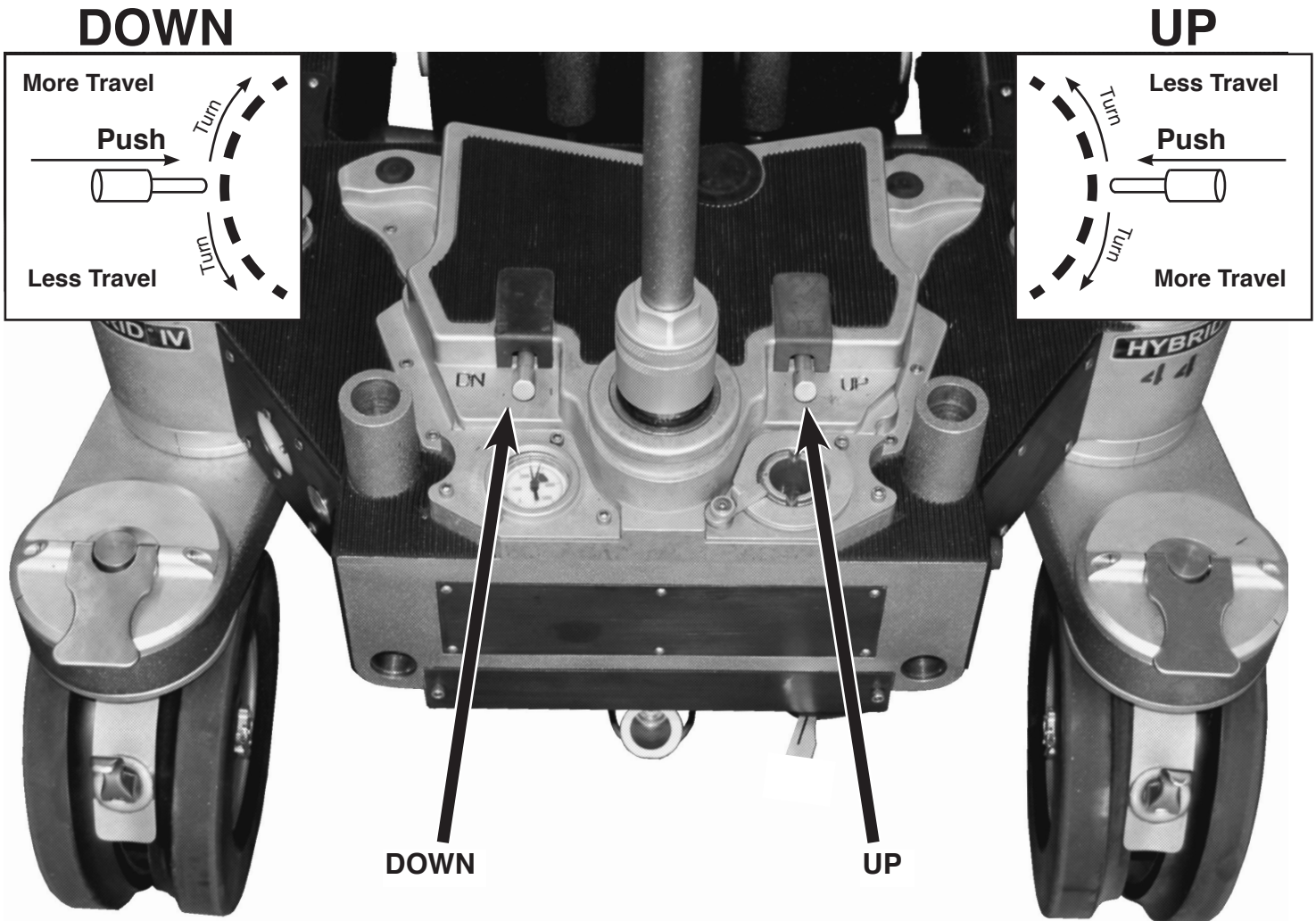

Looking down while standing at the rear of the Dolly.
Control Valve Handle removed for clarity.

When making Stop Adjustments:

1. Be certain the Arm is well beyond the desired Stop point. Then turn the Lever in beyond the desired Stop point.
2. Open the Main Control Valve to approach the desired Stop.
3. Open Lever to achieve movement until the desired Stop point is reached.
4. Close the Main Control Valve.

For rapid deceleration beyond the normal for this system, the Dolly Grip can use the Stop Valve to initiate the Stop, then finalize the Stop with the Main Control Valve.

Hybrid™ IV Fast Mode

A new feature of the Hybrid IV enables lowering the hydraulic arm when there is a small payload, or no payload to push the arm down when the control value is opened. The Fast Mode Value is located on the rear left side of the Hybrid IV. It is a by-pass of the Universal Stop Valve. During normal operation, the Fast Mode Valve is not used. The dial should be placed on the Normal Mode setting.

WARNING!

Before activating the Fast Mode feature, place the Control Valve in Neutral position. Failure to place the Control Valve in the Neutral position may cause the arm to drop unexpectedly into the chassis.

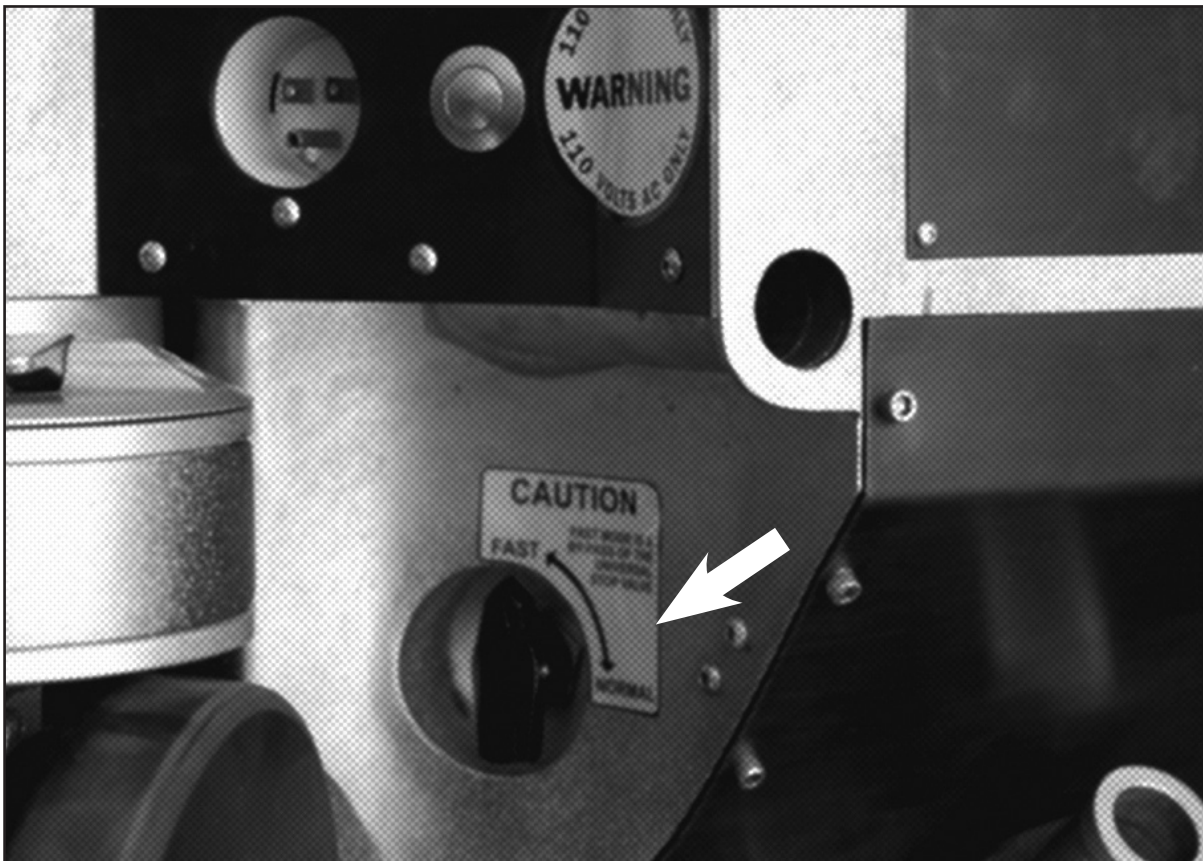

After the Fast Mode is activated, the Control Valve may again be used to raise and lower the arm quickly.

NOTE: When on fast mode, feathered stops of the Universal Stop Valve are deactivated. Therefore, if a situation calls for moving past a Feathered Stop, close the Control Valve (neutral position) and activate the Fast Mode Valve. The arm may then move past the upper & lower Feathered Stops without having to readjust their positions.

Hybrid™ IV Detent Bypass

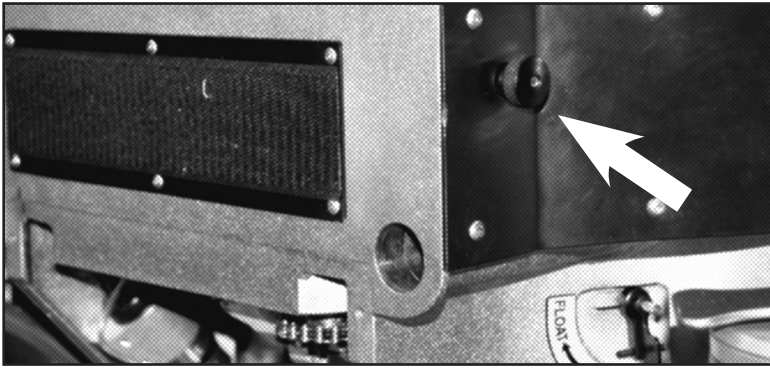

New to the Hybrid IV dolly is the ability to eliminate the detent feature of the Control Valve Handle. Pulling out the knob turns off the Detent feature. There are only two options; fully engaged or fully disengaged.

The Detent Bypass is ON when the button is pushed IN. It is OFF when the button is pulled out.

Hybrid™ IV Float Mode

A new feature of the Hybrid IV dolly is the ability to fine tune how the arm reacts to the Control Valve Handle. The default setting is for a detent zone of 5/16 inch in either direction. This zone can now be adjusted down to zero.

Located just below the Detent Bypass knob, the Float feature causes the arm to react instantly to a change in direction in moving up or down.

WARNING!

Before activating the Float Mode feature, place the Control Valve in the Neutral position. Failure to place the Control Value in the Neutral position may cause the arm to drop unexpectedly into the chassis.

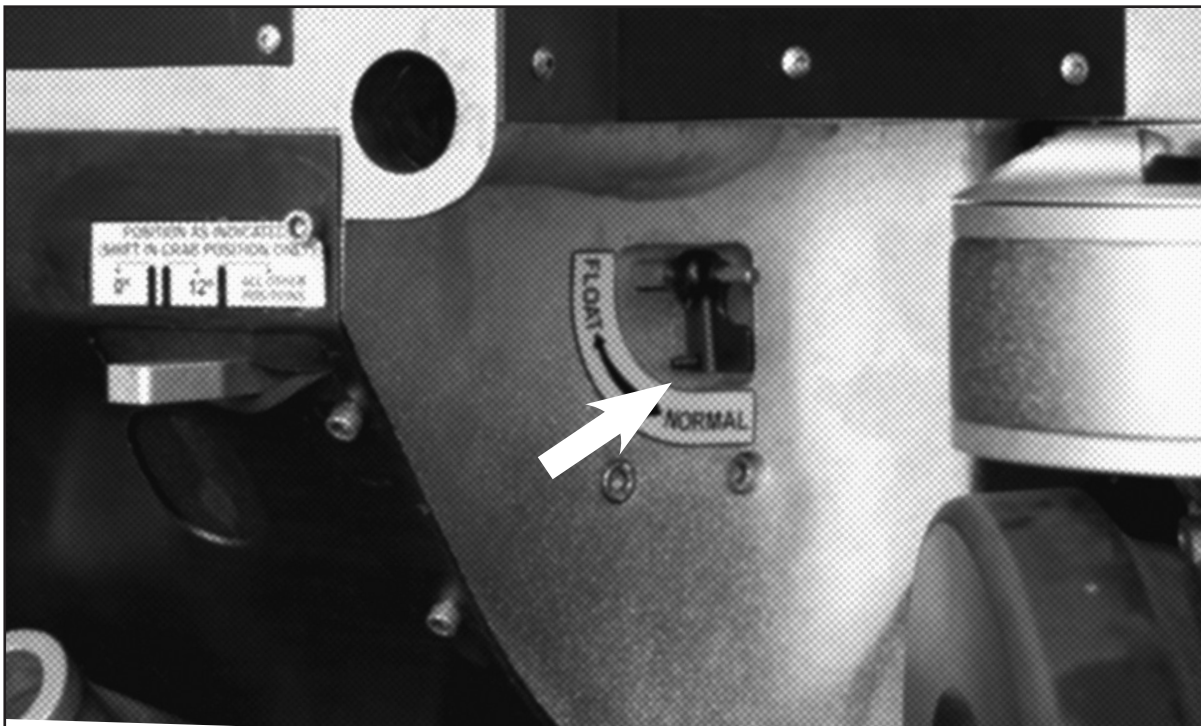

NOTE: When activating the Float Mode, the normal Detent or Dead Zone of the valve is eliminated. The motion of the Arm is now reverse direction without hesitation. Therefore, the Float position is achieved. Additionally the Grip can select their own Detent as preferred for a smoother transition from an upward or downward direction.

Hybrid™ IV Charging the Dolly - Electronically

A Female Plug can be inserted into the AC Receptacle (110v or 220v) located at the rear of the Dolly. Push the Start Button to begin automatic charging. The unit will stop charging when the Dolly Hydraulic System is fully charged.

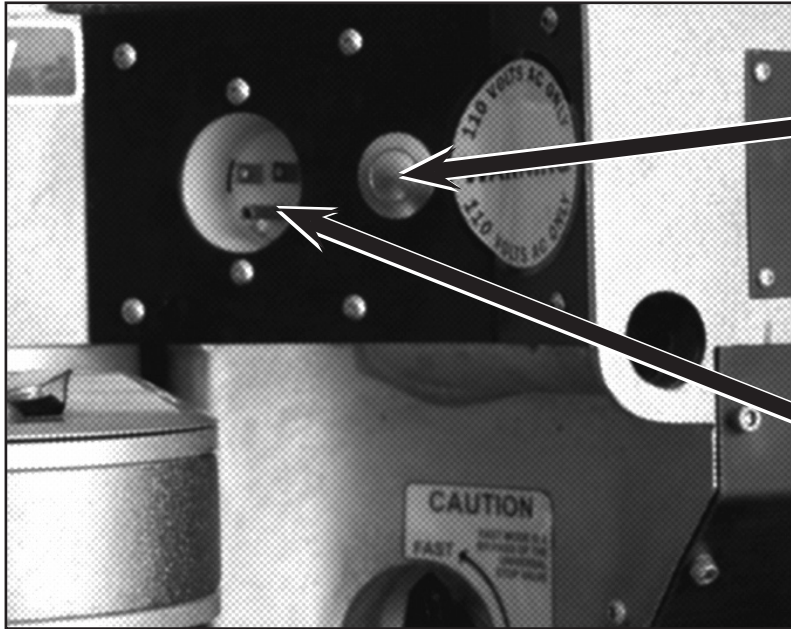

Start Button

For Optimal Safety

Only Use a Three (3) Prong Plugged Extension Cord to Maintain an Effective Electrical Ground

Plug Receptacle

Do not attempt maintenance on the Dolly when it is plugged into an electrical outlet.

Hybrid™ IV Charging the Dolly - Manually

Insert the Valve Control Handle into the Hand Pump Receptacle. Approximately 60 full strokes are needed to fully charge the Dolly system to 3100 psi. This pressurizes the nitrogen in the accumulators, which in turn moves the oil through the Hydraulic System.

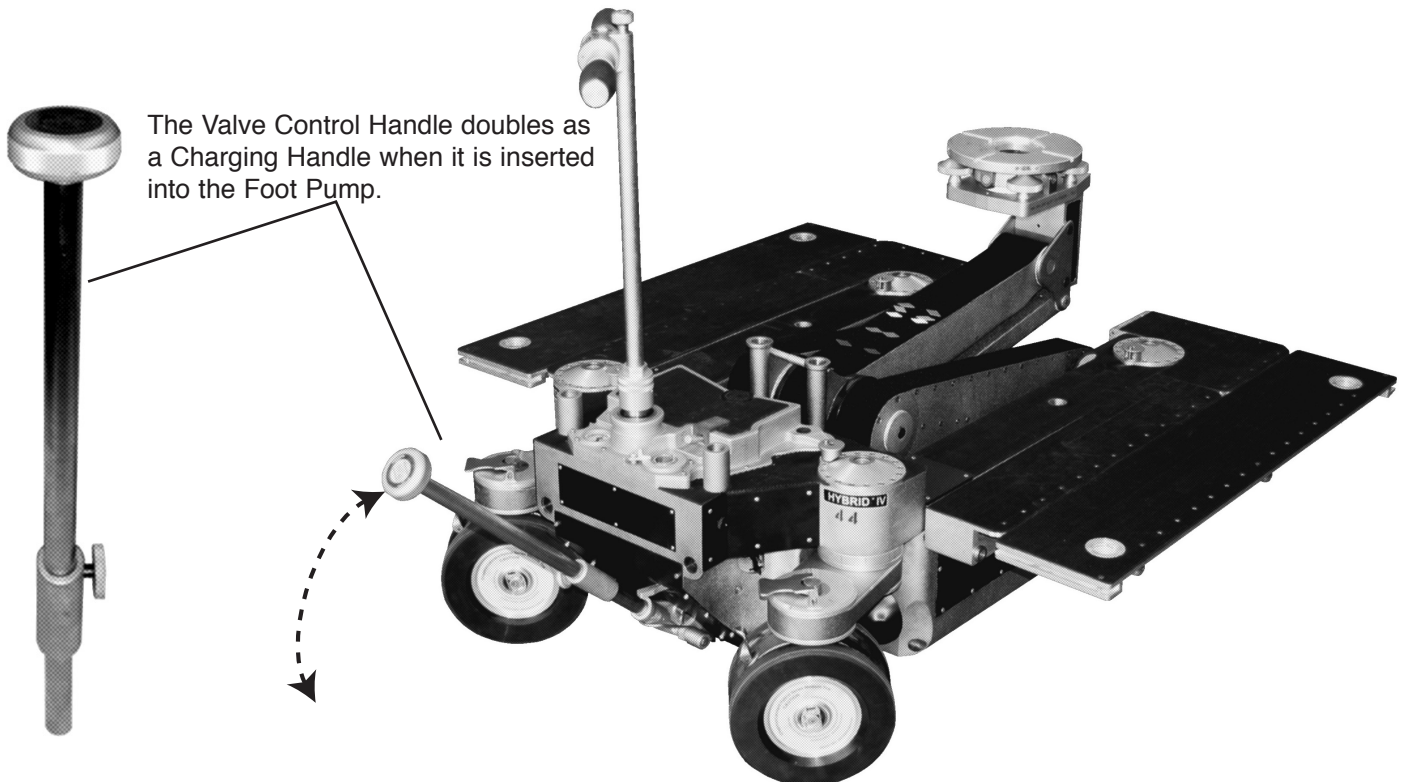

The Valve Control Handle doubles as a Charging Handle when it is inserted into the Foot Pump.

Hybrid™ IV Control Valve & Gauge

The Control Valve regulates the movement of the Arm. A fully charged system will read 3100 psi on the Pressure Gauge. This is enough pressure to enable 5 to 7 full strokes/lifts of the payload (camera). Total Payload = 700 lbs. @ 3100 psi. As a safety feature, the Relief Valve will open automatically at 3500 psi.

The Control Valve Handle has an adjustable detent system. Nothing happens in the Detent Zone. This clearance of 5/16 inch can be adjusted down to zero. In the Adjustable Detent Control System this can be felt as the handle is rotated and gives the Grip more control over the Arm as it transitions between up and down movements. The Off position is between the Detents.

A special Single or Triple Detent Control System is available, but must be installed at the Chapman facility or by a qualified technician.

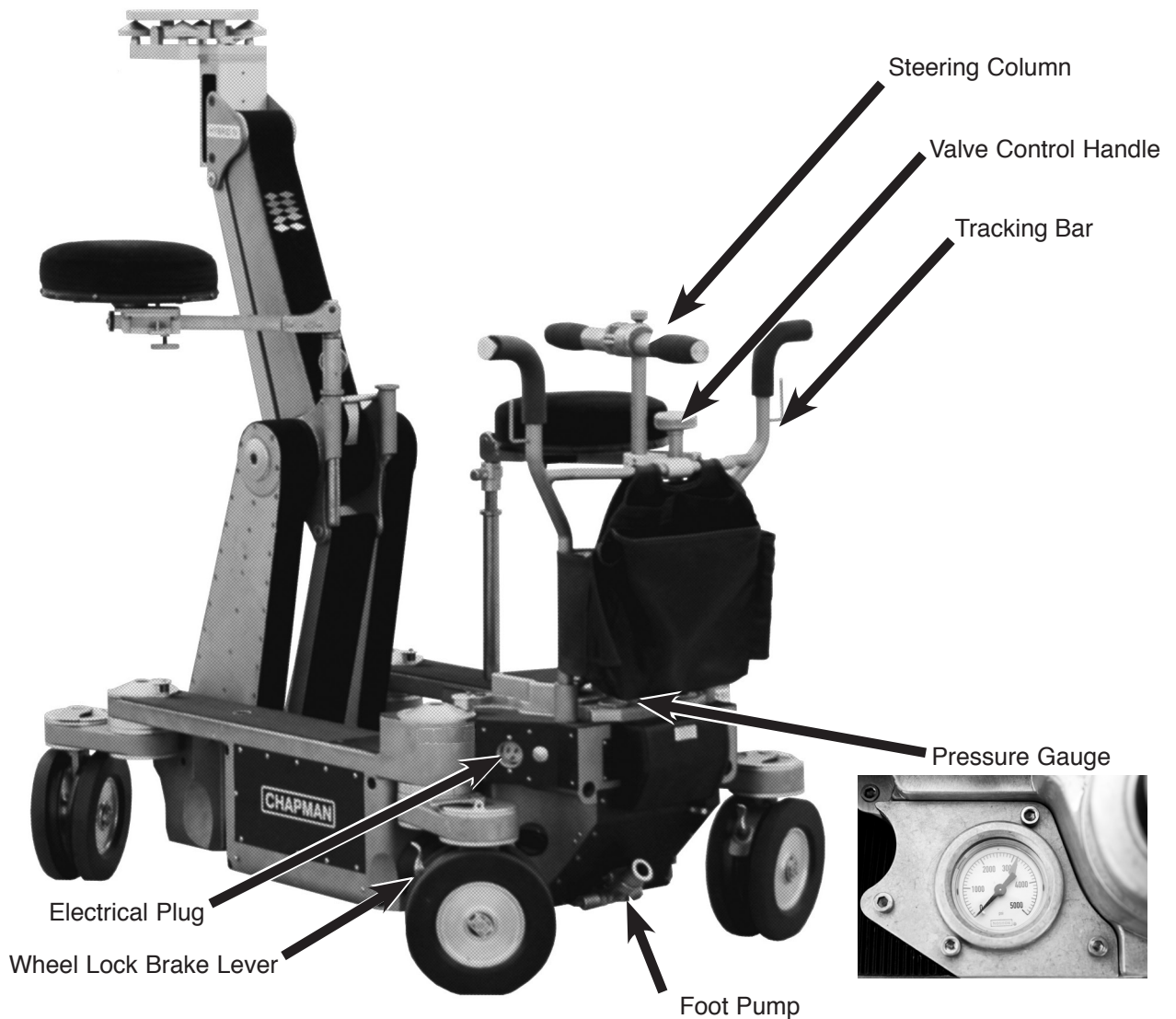

Hybrid™ IV Brakes

Brakes on each of the rear wheels hold the Dolly stationary between planned moves. The Wheel Locks are not intended for stopping the Dolly while in motion. The Hybrid IV should always be held in place with Blocks or Wheel Chocks when on any kind of incline.

Hybrid™ IV Leveling Head Choices

Changing from Under Slung to Over Slung Mode with the 90° Hi/Lo Plate

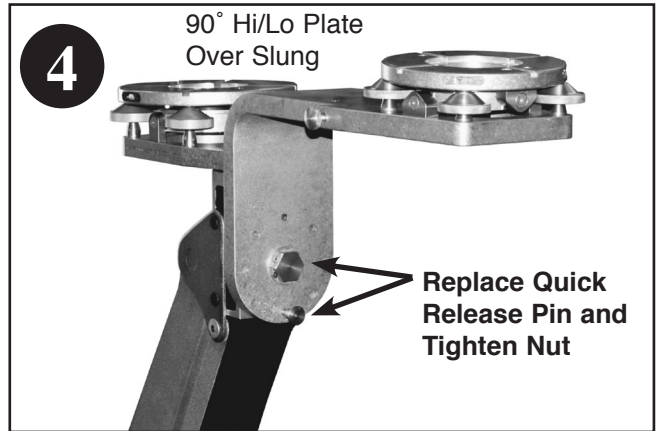
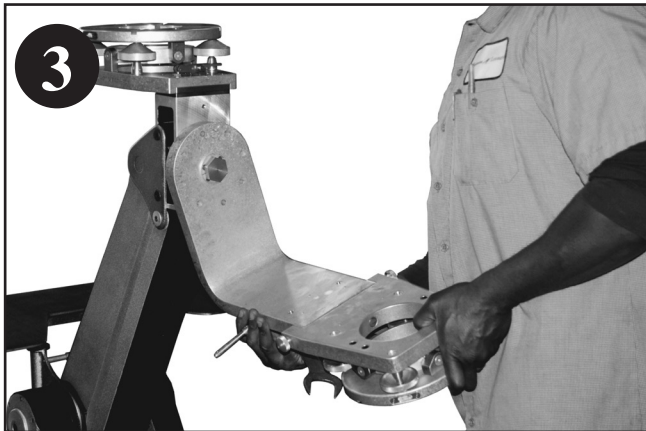
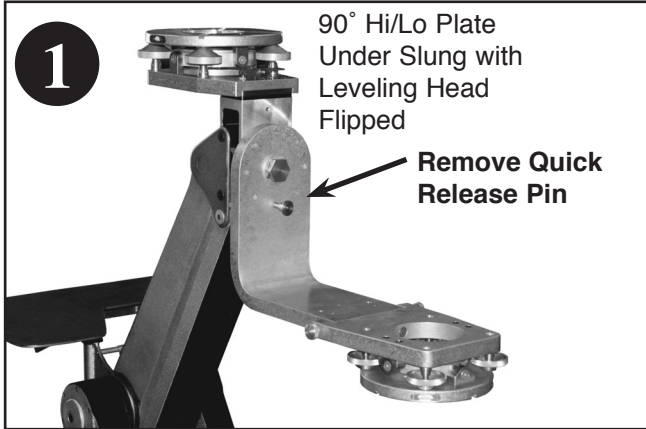

Other Leveling Head Options

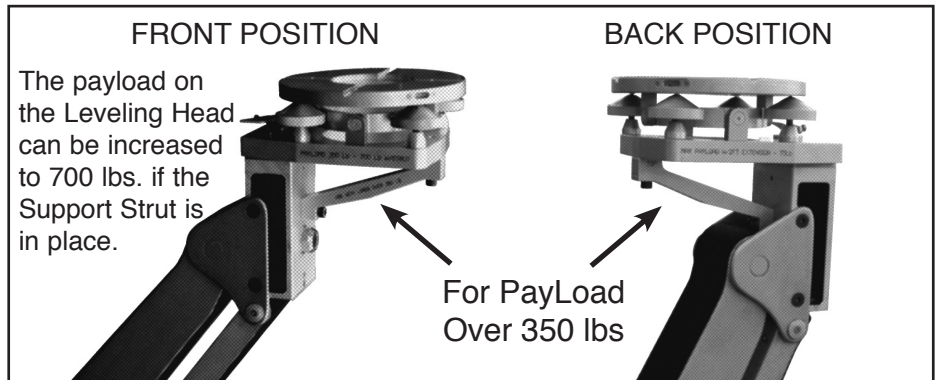
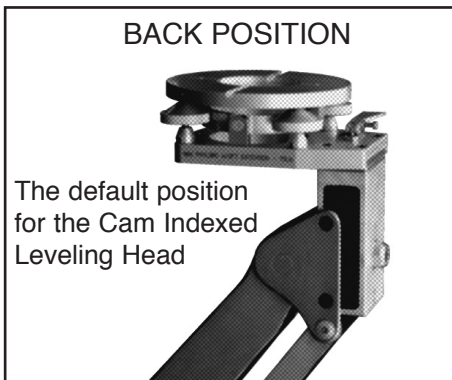
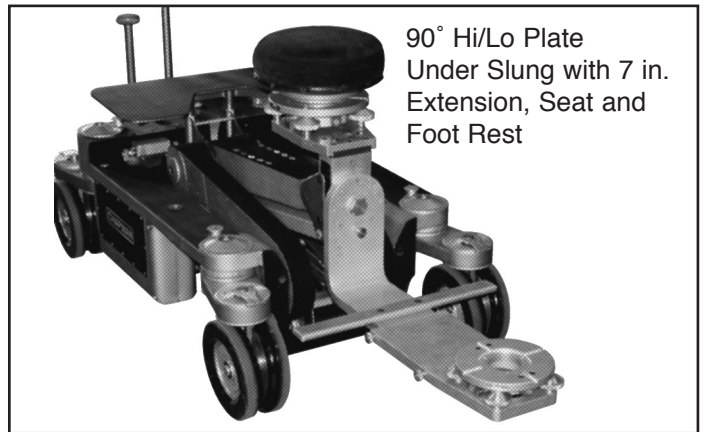
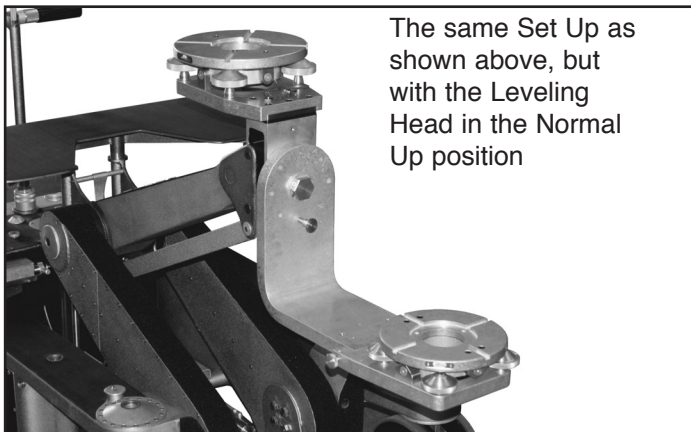

Hybrid™ IV Indexed GQ Leveling Head with Cam

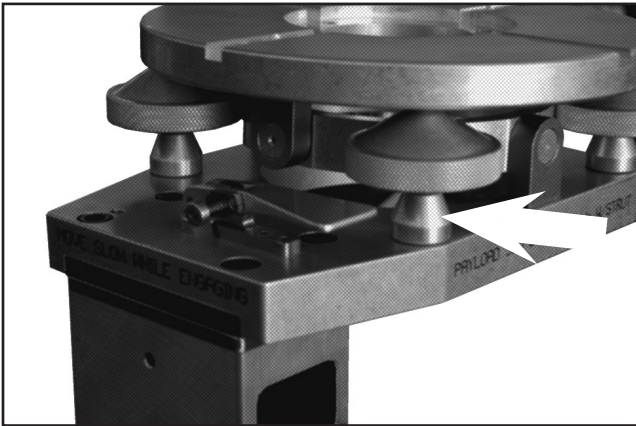

The Indexed GQ Leveling Head with Cam on the Hybrid IV is designed to minimize backlash and provide a rigid offset camera mount.

Push down on the Lever to disengage the locking pin. Hold the Lever down and turn the Leveling Head to any of the 20 positions (every 18 degrees).

Release the Lever and the 6 spring loaded pins lock the Head into place.



The Leveling Head can be made to freely rotate by depressing and holding the Lever, and then pushing the Cam Lever Button on the side. The Head will now rotate without locking into position.

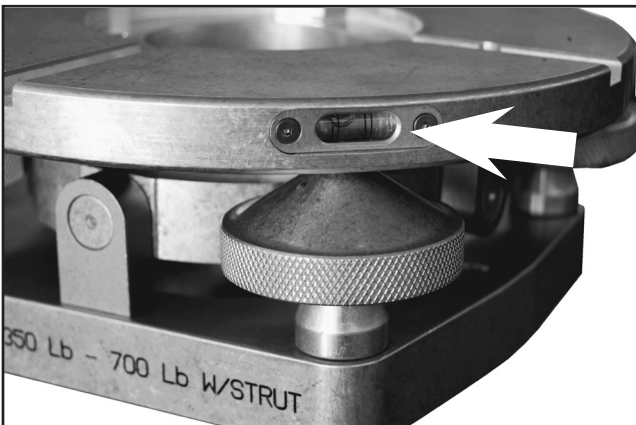

Leveling Bubbles on either side of the Leveling Head enable precise leveling of the Camera/Payload.

Now the Leveling Knobs can be adjusted to keep the Leveling Head level.



The Leveling Head is ready for operation when all four Leveling Knobs are in contact with the Mitchell Mount above. They should all be equally tightened by hand.

Hybrid™ IV Attaching Boards in Lower Walk-Around Mode

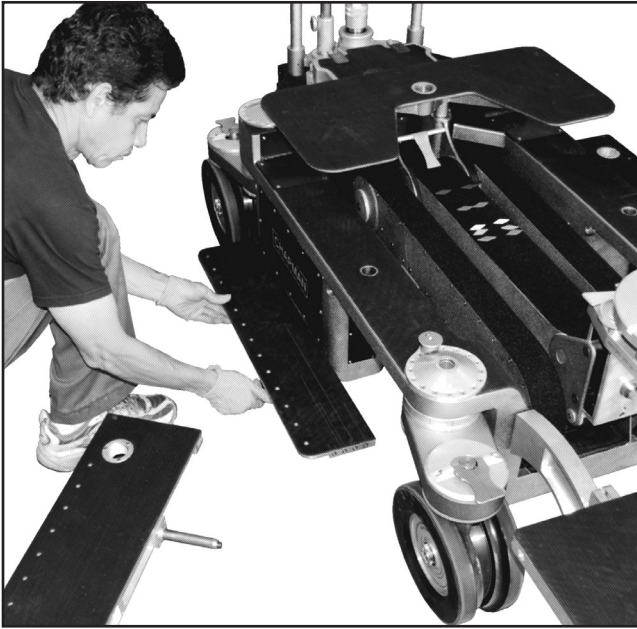

The Narrow Side Boards attach to either side of the Hybrid IV. They slide into place and are secured to the chassis with two thumb screws. As shown in this picture.

The Narrow Side Boards are right and left specific. They are not interchangeable from one side to the other.



The procedure for setting up the Standard Side Boards is the same. They are shown here being attached in the Low Mode Setup. The Standard Side Boards attach to either side of the Hybrid IV onto the Narrow Side Boards and they are interchangeable. They slide into place and are secured to the chassis with two thumb screws.

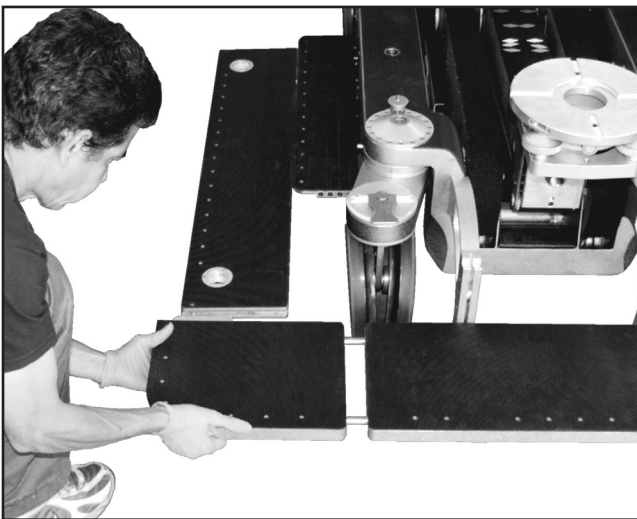

The Wide Corner Board slides onto the Front Standing Board with fixed rods. It is supported by a Tab that connects to the Standard Side Board.

Hybrid™ IV Attaching the Side Boards

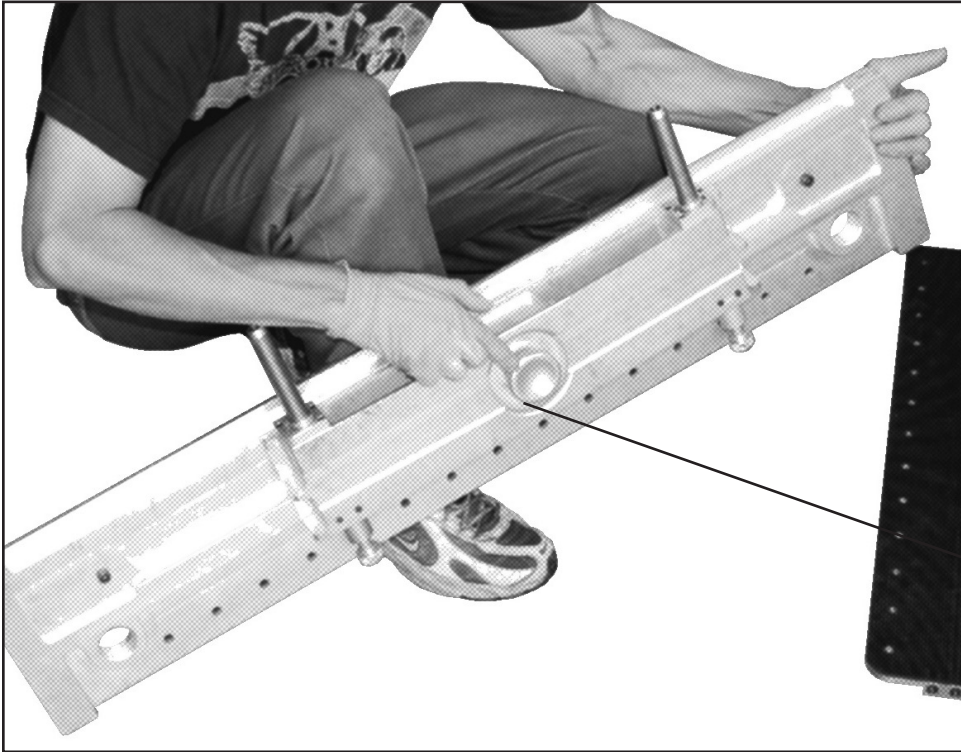

The Standard Side Boards are designed to be interchangeable. There is no left or right version.

The Standard Side Boards are also adjustable for and aft on the Hybrid IV chassis. A large knob secures the board to the desired location.

Position lock down knob.

The Side Boards may be moved to the rear of the Dolly for easy access to the front thumb screw. Then move the board forward to access the rear thumb screw.

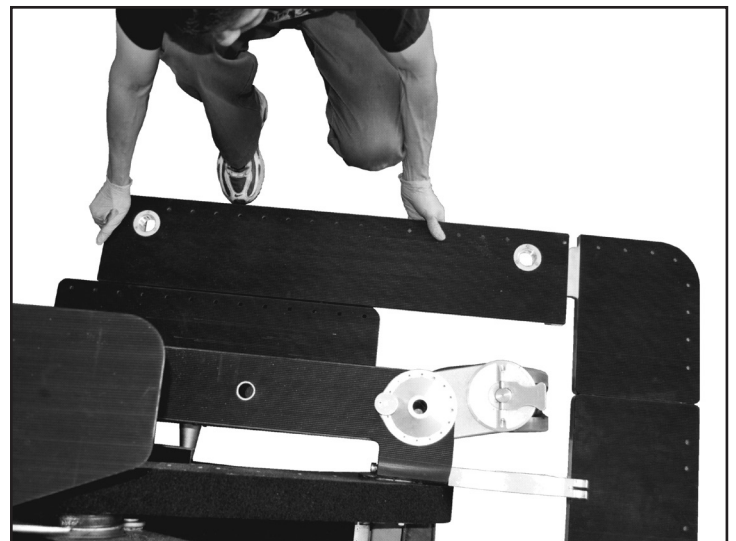

Hybrid™ IV Attaching The Adjustable Front Board

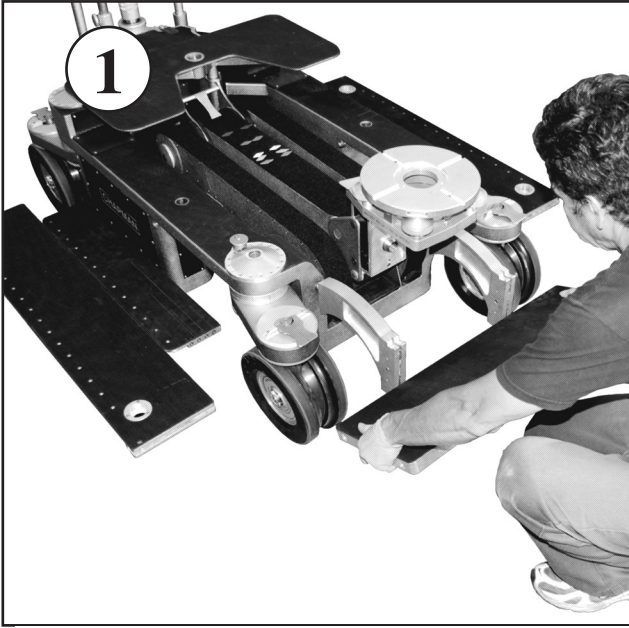

The Adjustable Front Board attaches with latches to the grooved pins.

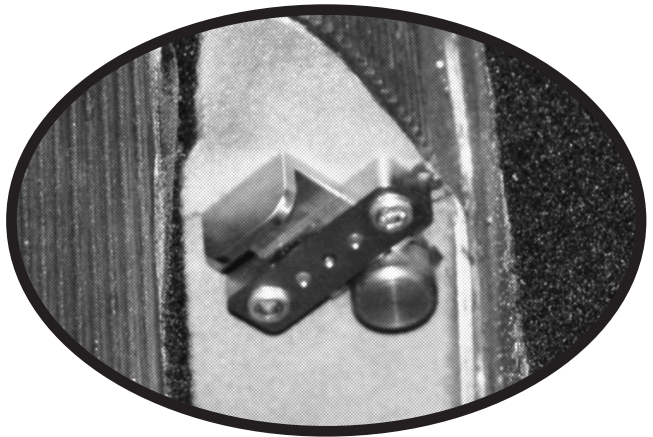
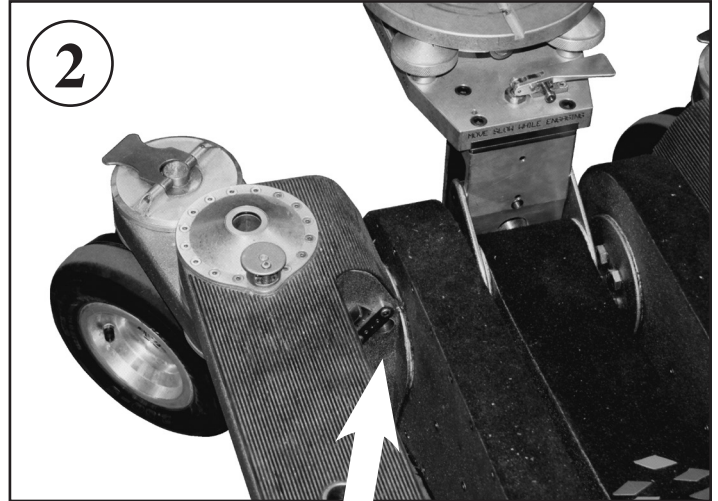

A latch is located on the Chassis to hold the Adjustable Front Board or the Lift Pins in place.

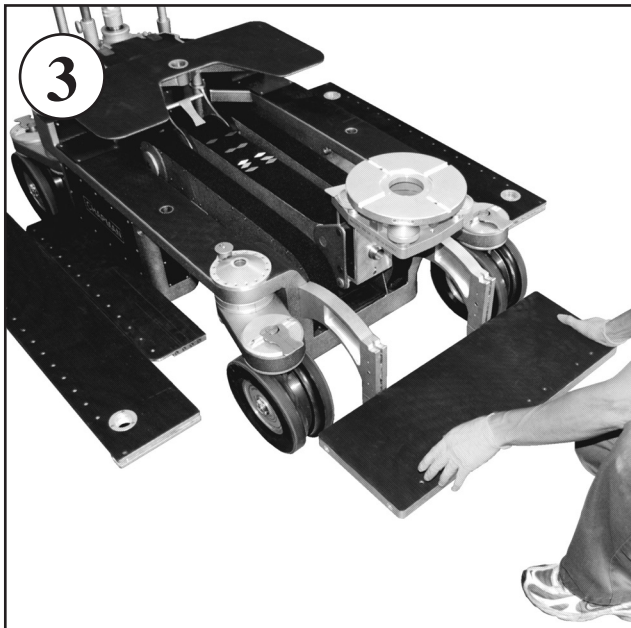

The Adjustable Front Board can be easily configured from high to low without removing the board.

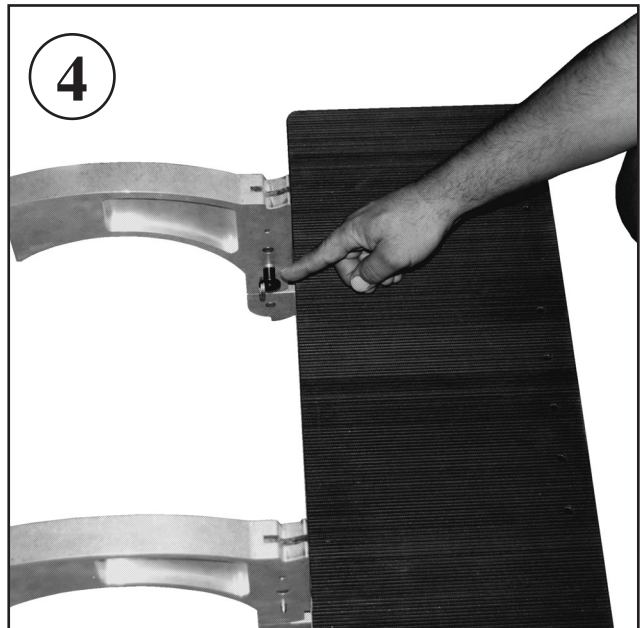

A Quick Release Pin secures the Adjustable Front Board in either the Upper or Lower position.

Hybrid™ IV Upper and Lower Board Setup Modes

With the Full Upper Side Board Set Up securely attached to the Hybrid IV, a stable platform allows the Grip to move the Dolly with a Camera Operator on board.

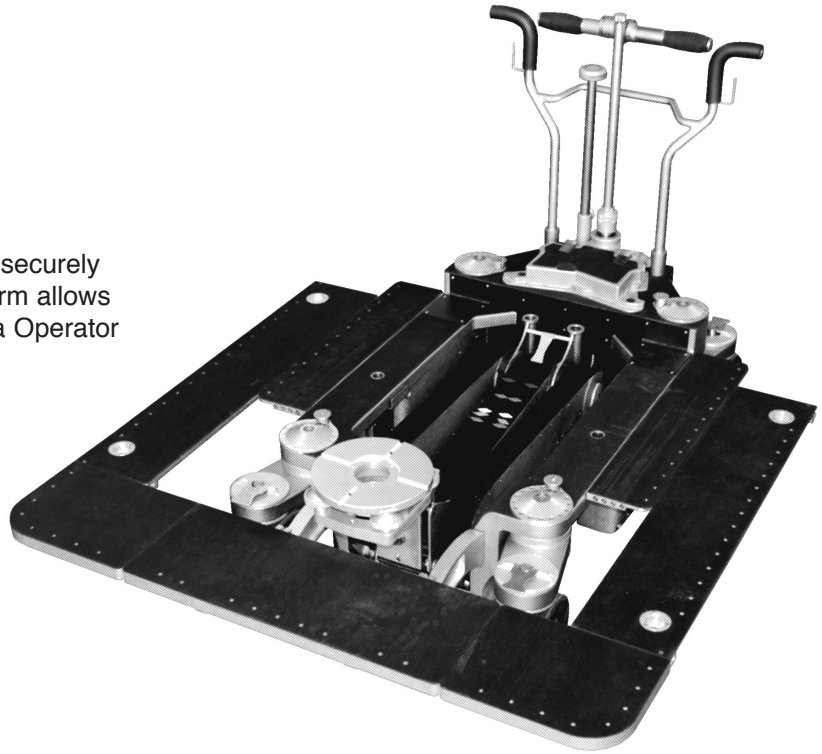

Full Lower Side Board Setup
with Boards extended forward.

Hybrid™ IV Side Board Configurations

Narrow Side Board Set Up

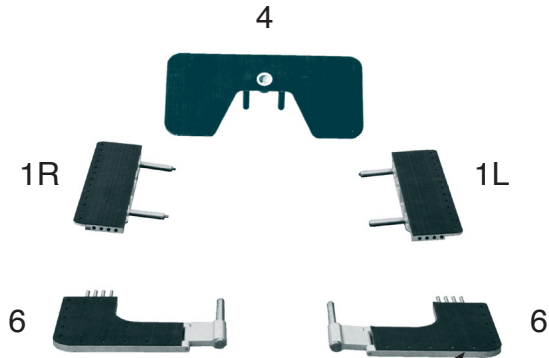

These Hinge Corner Boards are only used in the Upper Position.



Standard Side Board Set Up

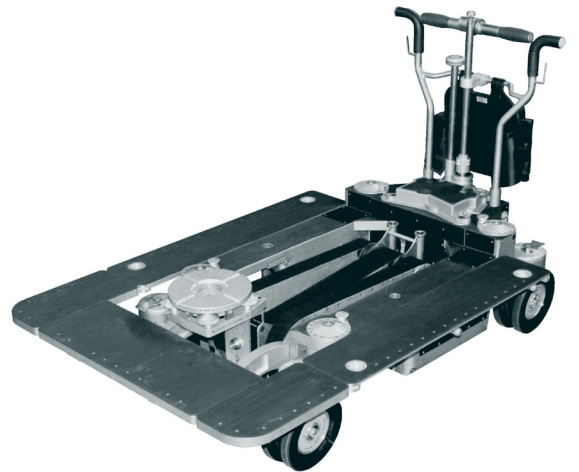
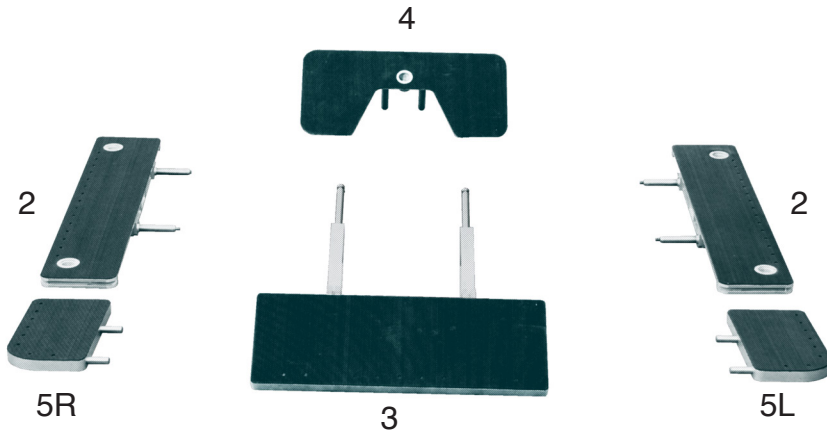

Full Side Board Set Up (Upper or Lower)

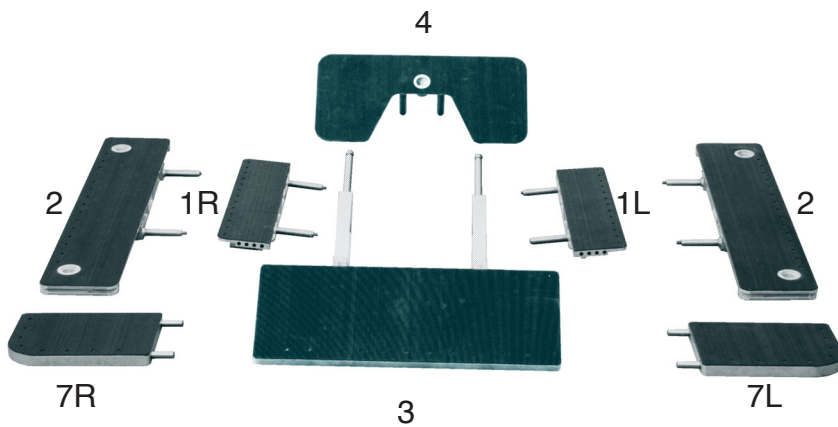

Hybrid™ IV Accessories

Quantity		Location	Number
1	Narrow Side Board (Left)	M R	1L
1	Narrow Side Board (Right)	M R	1R
2	Side Board (Interchangeable)	U L&R	2
1	Front Board (Adjustable)	U	3
1	Standing Board	U	4
1	Narrow Corner Board (Left)	M F	5L
1	Narrow Corner Board (Right)	M F	5R
2	Hinged Corner Board (Interchangeable)	M F	6
1	Wide Corner Board (Left)	M F	7L
1	Wide Corner Board (Right)	M F	7R
1	GQ Leveling Head Strut	M A	
1	Dolly Seat w/Collar	U A	
1	Swivel Seat w/Locking Pin	U F	
1	90° Hi/Lo Plate w/Leveling Head	M A	
1	90° Hi/Lo 7" Extension	M L	
1	90° Plate Hi/Lo Footrest	M L	
2	Front Lift/Push Bars	B	
2	Rear Lift/Push Bars	B	
1	12" Dolly Seat Riser	B	
1	12" Camera Riser	M R	
1	6" Camera Riser	M R	
1	3" Camera Riser	M R	
1	Castle Ring Wrench	B	
1	Seat Offset	B	
1	Dolly Nose Seat	M A	
1	16" Camera Extension	M L	
1	24" Camera Extension	M L	
1	Standard Hybrid 4-Way Level Head w/Nose L Plate	M A	
1	Standard 90° Low Camera Plate	M A	
1	Close End Wrench, Hybrid	B	
1	12" Tracking Bar Extensions	B	
1	Chapman Quick Jack	B	
1	Accessory Cart Cover	B	
1	Hybrid IV User Guide	B	



Hybrid™ IV Storing the Accessories

LEGEND

- U Upper
- M Middle
- B Bottom Carriage
- L Left Side
- R Right Side
- F Front
- A Aft (Rear)

- 16" Camera Extension
- 24" Camera Extension



Left Side



Right Side

Hybrid™ IV Quick Release Wheel Locks

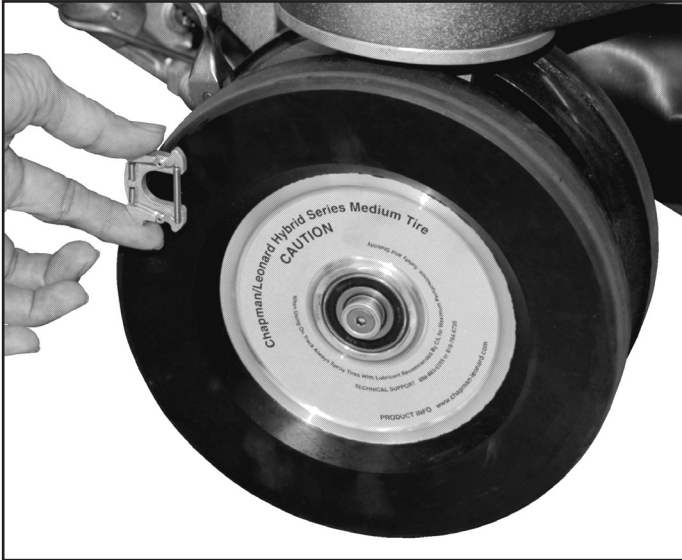

Changing a Wheel is a fast and easy procedure. Each wheel is held in place with a Quick Release Wheel Lock.

Spray the tires with Zep Par NC Silicone Spray (Key Words on Label "Mold Release Agent"). This will improve performance on Floors, Hardwood, Track and even on Concrete. That's because friction is the culprit behind tire squeaks and the tendency of tires to stick to track or polished floors. Treated tires begin rolling and run through turns with only moderate force.

Use the same spray to clean the tires.



Slide the Quick Release Wheel Lock into place on the axle. The spring will snap into place.



The Wheel is now secure.

CHAPMAN Quick Jack - Item #55170

FOR USE WITH ALL CHAPMAN DOLLIES

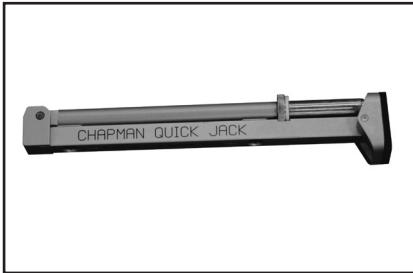

The Quick Jack in stowed position.

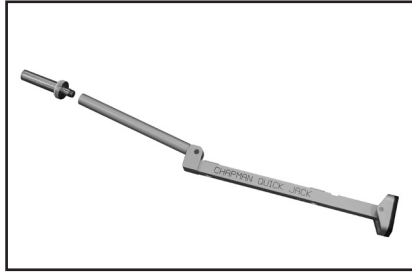

Extended with Peg detached.

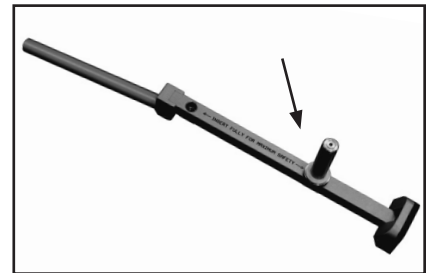

Peg attached to Lower Hole.

Tires can be quickly changed on the Hustler dolly by using the Quick Jack.

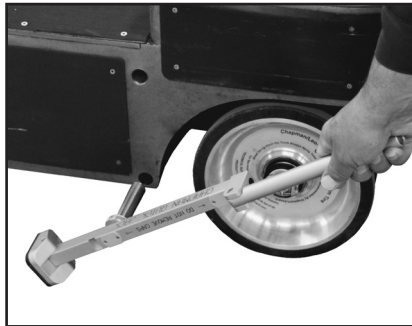

The Hustler Quick Jack inserted into the lower rear Side Board Hole.

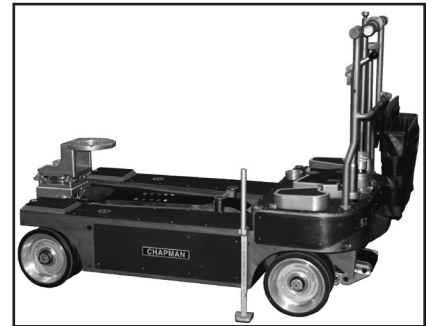

Easily lifts the **Hustler** dolly for a tire change.

The Quick Jack can be used on any Chapman dolly by attaching to a different side board hole.

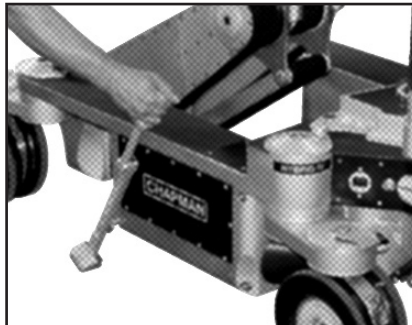

The Hybrid Quick Jack inserted into the lower center Side Board Hole.



Easily lifts the **Hybrid** dolly for a tire change.

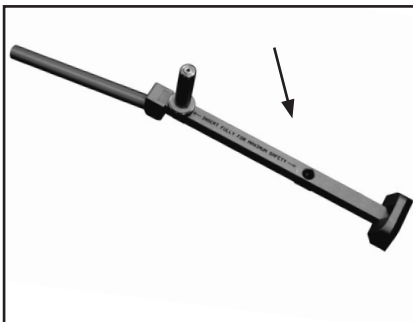

Attach the Peg to the Upper Hole on the Quick Jack to lift a PeeWee.



The PeeWee Quick Jack inserted into the center Side Board Hole.



Easily lifts the **PeeWee** dolly for a tire change. Then, apply the brakes.

Hybrid™ IV Cleaning the Hybrid™ IV



For Metal



For Rubber and Plastic

Always begin cleaning the Dolly with a Vacuum Cleaner. Never use an air hose, because dirt and metal shavings will find their way into joints and bearings. This can seriously shorten the life of the Dolly.

Never directly spray the Dolly with water. Use soap and water applied to a cloth or paper towel, or preferably a brush to wipe down the rubber and metal parts of the Dolly.

Wax the exterior of the Dolly using Megular's Mirror Glaze Cleaner Wax. This keeps the Dolly cleaner during regular use and preserves the finish. A clean Dolly will ensure optimum performance with smooth and quiet movements, while enhancing its aesthetics.

Spray the tires with Zep Par NC Silicone Spray (Key Words on Label are "Mold Release Agent"). This dramatically improves Tire Performance on Tile Floors, Hardwood, Track and even on Concrete. Use the same spray to clean the Tires.

ALWAYS READ WARNING LABELS

Hybrid™ IV Optional Accessories

The Extended Tracking Bar allows the grip to move the dolly without touching the steering handle.

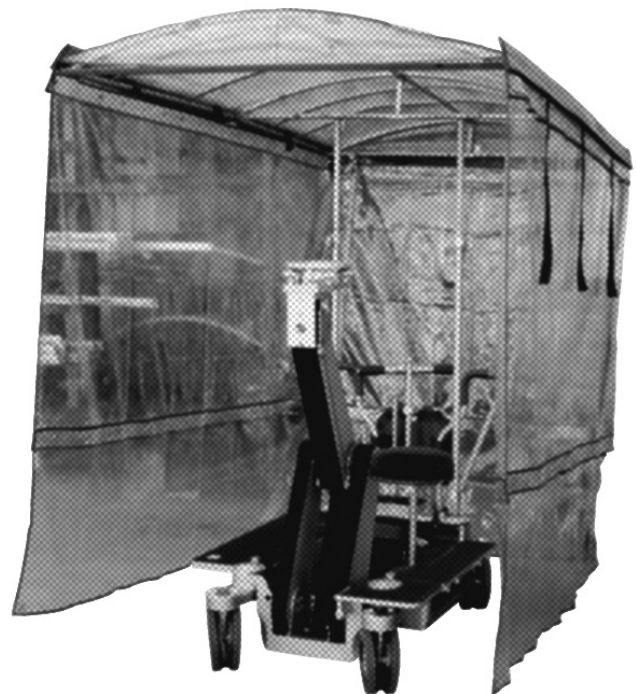
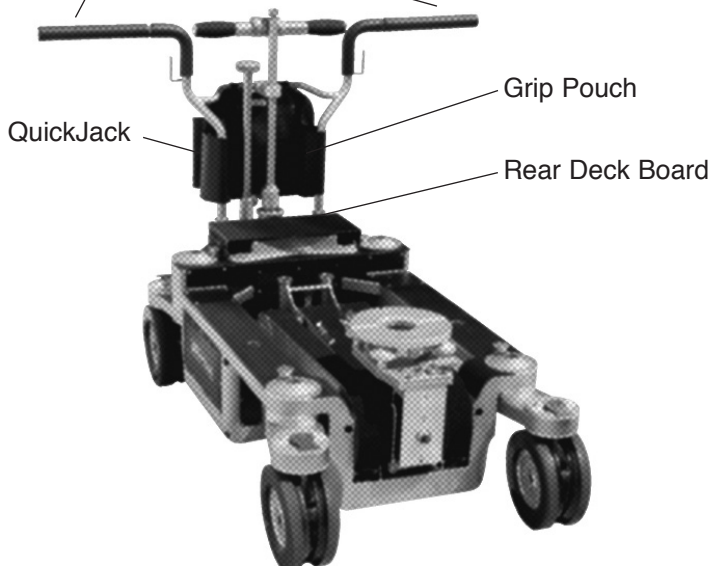

The optional Rainhouse protects the camera and operator from the elements. Also available in an opaque sunshade version.

Hybrid™ IV Packing the Dolly for Transport

You can use the Lifting Bars from the Accessory Cart to remove the Dolly from the packing crate. Be sure the Lifting Bars are fully seated and the Retaining Pins are projecting below the Dolly. The stripped down weight of the Hybrid IV is 395 lbs.



Use all four Carrying Bars when carrying the Dolly. Attempting to make a move with only one Carrying Bar per end or per side may cause injury.

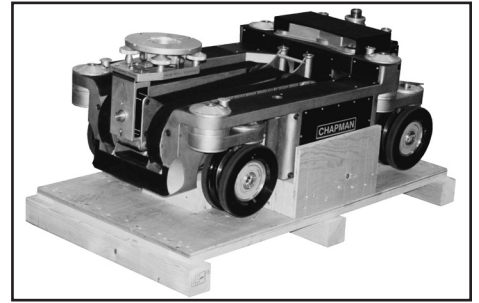
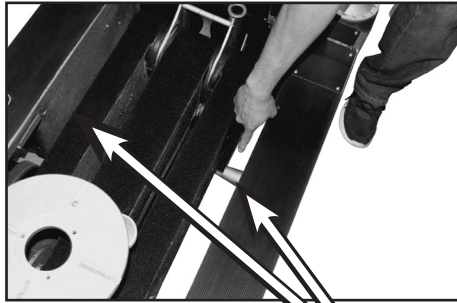
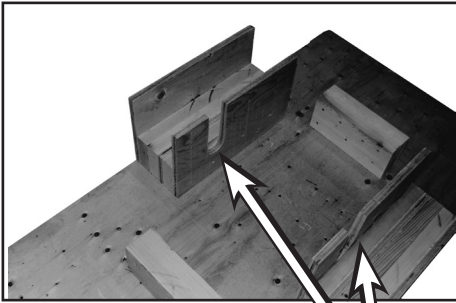

The dolly is cradled and no additional bolts or straps are needed.

Two notches in the crate engage the dolly at these points.



Remove the **Lifting Bars** from the dolly and place them in the crate.



There is enough room for all of the Accessories that come off the Hybrid IV to be placed in or on the Accessory Cart.

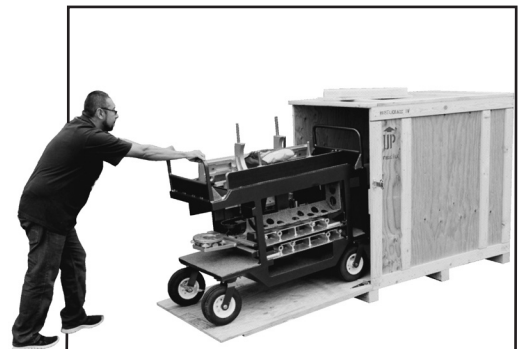

One side of the Accessory Cart Crate can be lowered to form a ramp. The Accessory Cart can then be wheeled into its own crate for shipping.

Hybrid™ IV Shipping and Rental Return

Dolly must be properly crated before shipment.

Make sure to attain a signed receipt from your chosen transport company to confirm shipment.

Rentals bays are located on the left, immediately after entering the Chapman / Leonard facility.

Trucks should be backed into the bays for easier loading.

If no bays are available, please park on Raymer Street and advise the Rental Office of your arrival.

A customer service agent will notify you once a space becomes available.

All drivers must report to the rental office to process paperwork before unloading may begin.

Our Rental Staff is well trained to process equipment and documents efficiently

*ALL RENTALS must be returned by 10:00 AM at the North Hollywood Facility.

Rental Office Hours:

Monday - Friday: 7:00 AM – 6:00 PM

Saturday: 8:00 AM – 12:00 PM

Sundays: CLOSED

