

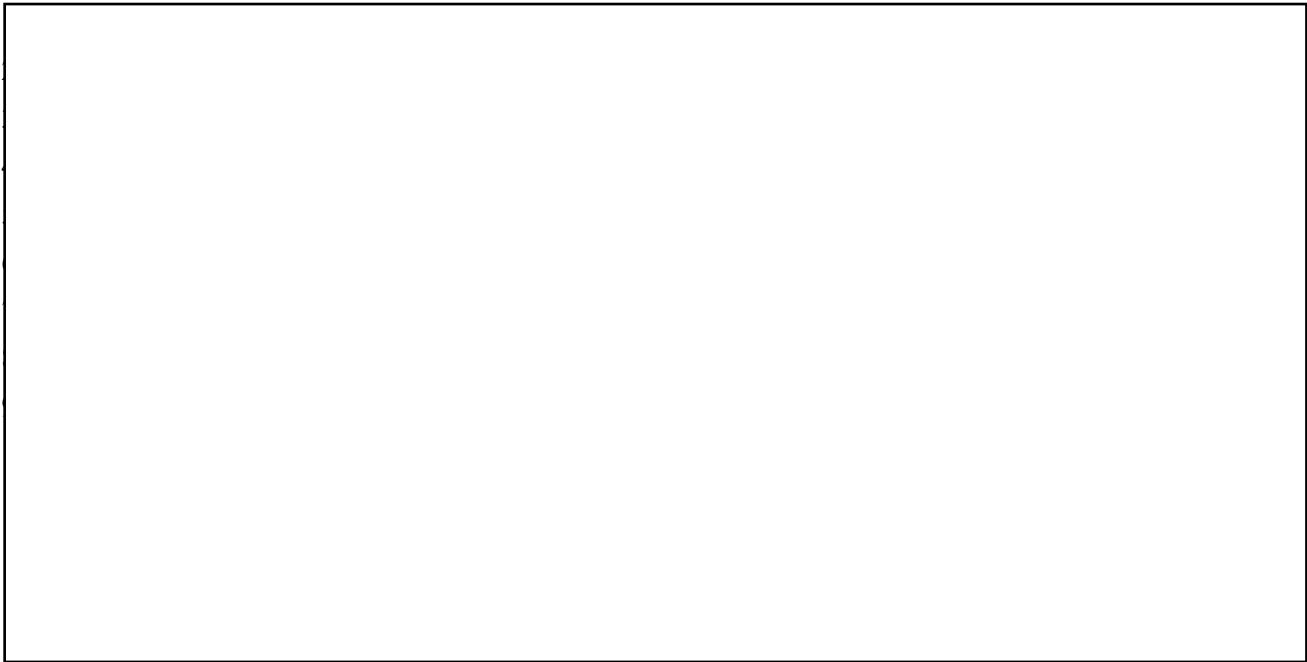

**HZ-100**  
**Haze Machine**  
**User Manual**  
**- English**  
**- 中文**



1. Introduction .....	1
2. Safety Information.....	1
3. Package Contents & Inspection.....	2
4. Machine Details.....	3
5. Technical Label Information.....	3
6. Haze Fluid.....	3
7. Setting and Manual Operation.....	3
8. Control Settings.....	4
9. HC-1 Timer Cable Remote (Optional) .....	4
10. HCR-1 Wireless Remote (Optional).....	5
11. Service and Maintenance.....	5
12. Technical Specifications .....	5
13. Warranty Disclaimer .....	6
14. Machine Dimension.....	6



Appendix I Grounding Instruction .....	13
--	----

# HZ-100



★★★★★ H A Z E R ★★★★★

## *User Manual*

### 1. Introduction

Please read all the user manual before operating the machine, and place the manual where the user can refer to it at all time. The manual includes how to install and operate the machine under safe conditions and explain all the labels printed on the machine. If you encounter any problem, contact your local Antari dealer for assistant immediately.

### 2. Safety Information

 <b>DANGER</b>	If the danger is not avoided, it will cause death or serious injury
 <b>WARNING</b>	If the warning is not heeded, it can cause death or serious injury.
 <b>CAUTION</b>	If the precaution is not taken, it may cause minor or moderate injury.



#### **DANGER**

- Must connect the machine to the correct rated voltage or it might lead to an electrical shock or a burn and may cause serious consequences.
- Must connect the machine to a protected circuit and ensure it is properly grounded to avoid the risk of electrocution. For grounding instruction, please refer to Appendix I on page 13.
- Do not operate the machine with a bundled power cord, it could lead to a fire hazard.
- When operating the machine, do not point at people, animals, or fire.



#### **WARNING**

- Please operate the machine on a flat, level hard and well ventilated surface area, reserve at least 50cm space around the machine and make sure there is no flammable gas or material nearby.
- Do not disassemble, repair or modify the machine, it may cause damages, malfunction, risk of electrical shock or result in fire.
- The machine can only be operated by adults or professionals, is not intended for use by person with reduced physical sensory, mental capabilities, or lack of experience and knowledge including children.
- Do not leave the machine running unattended, make sure all powers are off when leaving.
- Children should be supervised to ensure that they do not play with the machine.
- Do not use the machine upside down or tilt it, it might cause damages or malfunction.
- Please store the fluid inside in a well ventilated area without direct sunlight and keep out of reach of children. In case of eye contact or accidentally swallow the fluid, please seek medical attention immediately.



#### **CAUTION**

- Keep the machine dry at all time. The machine is not waterproof, do not expose the machine to water, rain or moisture environment.
- Please make sure the power outlet is not damaged or loose before plug in the power cord.
- If the power cord is damaged, it must be replaced by Antari or its local dealers, otherwise the warranty will be

void.

- Before transporting the machine, please make sure the fluid is drained and tank is empty. (Recommend using original package)
- The machine is for indoor use only.
- Do not operate the machine in any area with unstable voltage.
- If you experience strange sound or malfunction, turn off the power and unplug the power cord immediately and contact your local Antari dealer for assistant.
- Do not contact any moving part.
- Only use accessories recommended or sold by Antari.
- Please make sure the power is off when not using the machine and unplug the power cord if not intend to use for a long period of time.
- To disconnect, turn all controls to the off position, then remove plug from outlet.
- Do not unplug by pulling on cord. To unplug, grasp the plug, not the cord.
- Unplug from outlet before servicing or cleaning.
- Do not operate the machine with a damaged cord or plug, or after the machine malfunctions or is dropped or damaged in any manner. Return machine to the nearest authorized service facility for examination, repair, or electrical or mechanical adjustment.
- To ensure the lifespan of the machine, please only use the fluid manufactured by Antari, do not use other fluid or additive, otherwise it may cause malfunction.

Before operating the machine, please read all warning labels on the machine, description as below;

Top Cover Printing

USE DEALER RECOMMENDED HAZE LIQUID ONLY!

DO NOT OPEN CASE RISK OF ELECTRIC SHOCK

**WARNING!**

PLEASE USE RECOMMENDED, NON-FLAMMABLE FLUID ONLY. MAKE SURE THAT THE LIQUID LEVEL DOES NOT EXCEED THE MARK AS MACHINE PERFORMANCE MAY SUFFER

Rear Cover Printing

**WARNING!**

DISCONNECT POWER BEFORE CHANGING FUSE.

USE ONLY WITH ADULT SUPERVISION.

DO NOT OPERATE WITHOUT LIQUID.

FOR INDOOR USE ONLY. KEEP DRY.

NO USER SERVICEABLE PARTS INSIDE.

**MAX. FLUID LEVEL**

MAKE SURE THAT THE LIQUID LEVEL DOES NOT EXCEED THIS MARK.

### 3. Package Contents & Inspection

Immediately upon receiving the machine, carefully unpack the carton, check the content to ensure it is the correct model and all parts are included. If any part appears to be damaged or missing during transportation, please contact your local dealer and return in original package for inspection.

#### 3.1 Package Contents

1 x HZ-100 Haze Machine

1 x IEC Power Cable

1 x User Manual or scan QR Code on the Machine



## 4. Machine Details

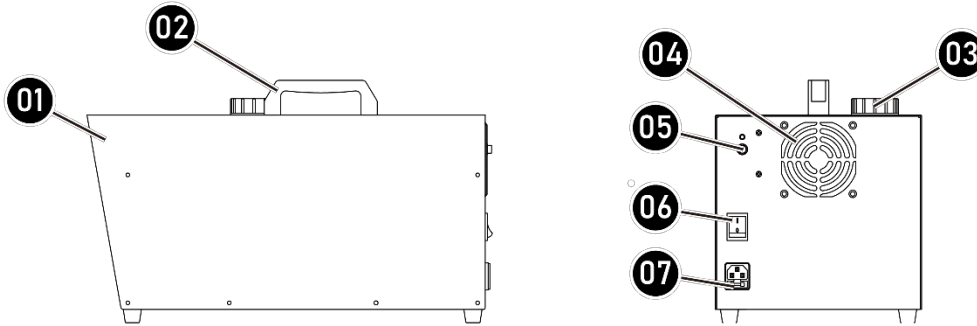

01. Fog Nozzle	05. Cable Remote Input
02. Handle	06. Power Switch
03. Fluid Tank Cap	07. IEC Power Connector
04. Fan	

## 5. Technical Label Information

Please read the technical label information on the back of the machine before operating it.

1. Model Name	5. Breaker/Fuse
2. Input Voltage	6. QR CODE for User Manual
3. Frequency	7. Serial No.
4. Rated Power	

## 6. Haze Fluid

	<b>CAUTION</b>	Always turn off the power before filling the fluid tank. Do not add flammable liquid to the fluid tank. If fluid gets inside the machine, please contact your local Antari dealer for assistant.
--	----------------	--

- Only the haze fluid manufactured by Antari can be used, do not mix or dilute the haze fluid. Due to improper storage or using other fluid might cause malfunction.
- The machine is tested and calibrated with the specific haze fluid to get the best performance.
- Please empty the fluid in the tank before switching to another fluid to avoid mixing.
- The warranty on your haze machine will be void if you use haze fluid not manufactured by Antari.

## 7. Setting and Manual Operation

	<b>WARNING</b>	Machine falling off might cause serious injury, please make sure it is secure and firm on the overhead.
--	----------------	---

- Step 1.** Place the machine on a flat, level hard and well ventilated surface area and reserve at least 50cm open space around the machine, and make sure there is no flammable gas or material nearby;
- Step 2.** Fill with Antari approved haze fluid;
- Step 3.** Connect the machine to the power outlet. Please read the technical label on the back of the machine and make sure the power outlet is the correspond to the rated voltage for the machine;
- Step 4.** Turn on the power, the machine will start hazing and turn off the power, the machine will stop hazing;
- Step 5.** To turn off the machine, please make sure the machine is not operating then turn of the power. If you will not use the machine a long period of time, please remove the power cord.



## 11. Service and Maintenance



**DANGER**

Disconnect the power cord before starting maintenance operation!

- Always keep the machine clean.
- Can use an air compressor, a vacuum or a soft brush to remove the dust on the machine.
- Can use a slightly damp cloth to clean the casing.
- Before store or after use the machine, please make sure the fluid box is empty and dry.
- It is recommended to run the machine at least once a month in order to maintain its best performance and output condition.
- Excessive dust and build up liquid residue will reduce the performance and cause overheat.

## 12. Technical Specifications

<b>HZ-100</b>	
<b>Input Voltage</b>	US Model : AC 100-120V, 50/60Hz 3.5A EU Model : AC 220-240V, 50/60Hz 2.0A
<b>Rated Power</b>	390W
<b>Fluid Consumption</b>	0.7 ml/min (100% output)
<b>Fluid Tank Capacity</b>	2.5 Liters (0.66 gallon)
<b>Compatible Fluid</b>	Antari HZL Haze Fluid
<b>Operating Time</b>	60 hrs (100% output)
<b>Ambient Temp. Range</b>	0°C – 40°C (32°F – 104°F)
<b>Control Methods</b>	Manual 、 Timer (Optional) 、 Wireless (Optional)
<b>Interface</b>	IEC (Power)
<b>DMX Channels</b>	N/A

<b>Included Accessories</b>	N/A
<b>Optional Accessories</b>	HC-1 Timer Cable Remote 、 HCR-1 Wireless Remote
<b>Dimension</b>	L 484 W 250 H 294 mm (L 19.06 W 9.84 H 11.57 inch)
<b>Weight</b>	13.2 kg (29.10 lbs.)

### 13. Warranty Disclaimer

We guarantee the merchandise manufactured by us to be free from defect in material and workmanship for a period of one year. Our obligation and liability under this warranty shall be restricted to repair or replacement at our factory or local authorized dealer. We assume no liability of the products that are improperly used or used for any purpose other than that for which they are specially designed. This warranty shall not apply to any merchandise which has been repaired, altered or assembled outside our factory in any way so as in our judgment to affect its performance, nor which has been subjected to misuse, negligence, or accident nor to any merchandise operated contrary to our printed instructions. We will not allow or be liable of any loss or any damages of any kind in connection with the use, sale, or repair of any merchandise purchased from us.

### 14. Machine Dimension

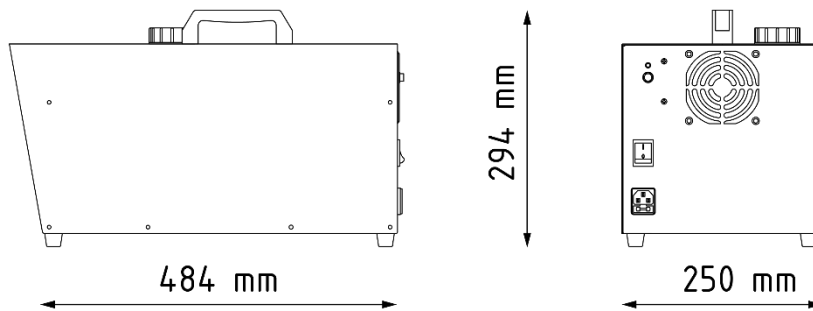

## Appendix I Grounding Instruction

This appliance must be grounded. In the event of malfunction or breakdown, grounding provides a path of least resistance for electric current to reduce the risk of electric shock. This appliance is equipped with a cord having an equipment-grounding conductor and a grounding plug. The plug must be plugged into an appropriate outlet that is properly installed and grounded in accordance with all local codes and ordinances.

**DANGER** – Improper connection of the equipment-grounding conductor can result in a risk of electric shock. The conductor with insulation having an outer surface that is green with or without yellow stripes is the equipment-grounding conductor. If repair or replacement of the cord or plug is necessary, do not connect the equipment-grounding conductor to a live terminal. Check with a qualified electrician or serviceman if the grounding instructions are not completely understood, or if in doubt as to whether the appliance is properly grounded. Do not modify the plug provided with the appliance – if it will not fit the outlet, have a proper outlet installed by a qualified electrician.

This appliance is for use on a nominal 120 V circuit, and has a grounding plug that looks like the plug illustrated in sketch A in Figure. A temporary adaptor, which looks like the adaptor illustrated in sketches B and C, may be used to connect this plug to a 2-pole receptacle as shown in sketch B if a properly grounded outlet is not available. The temporary adaptor should be used only until a properly grounded outlet can be installed by a qualified electrician. The green colored rigid ear, lug, and the like, extending from the adaptor must be connected to a permanent ground such as a properly grounded outlet box cover. Whenever the adaptor is used, it must be held in place by the metal screw.

