



**CHAPMAN/LEONARD**  
— STUDIO EQUIPMENT INC. —

## **Super Peewee® IV / Super PeeWee® IV+**

User Manual

Operational Instructions & Specifications

# Super Peewee® IV / Super PeeWee® IV+

User Manual

Operational Instructions & Specifications

July, 2021 | Edition 20

**CHAPMAN**

## Chapman/Leonard Certified Locations

### Main Office

12950 Raymer Street,  
North Hollywood, CA 91605

### Toll Free:

(888) 883-6559  
(818) 764-6726

### FAX:

Rentals: (818) 764-6730  
Leasing: (818) 764-4347  
Accounting: (818) 764-9391

### Florida

9460 Delegates Drive  
Orlando, Florida 32837

### Toll Free:

(888) 337-8243  
(407) 851-3456

### FAX:

(407) 855-1653

### Louisiana

668 Distributors Row Suite E  
Elmwood Business Park  
New Orleans, LA 70123

### Toll Free:

(888) 758-4826  
(504) 731-6050

### FAX:

(504) 731-6051

### Texas

1901 E. 51st Street  
Austin, Texas 78723

### Toll Free:

(888) 758-4826  
(512) 473-0084

### FAX:

(512) 473-0042

**Georgia**

500 Sandy Creek Road BLDG 2004-101  
Fayetteville, GA 30214

**Toll Free:**

(888) 758-4826

**FAX:**

(678) 583-1858

**UK & Europe**

Chapman Leonard Studio Equipment, Ltd.  
Unit 2 and Unit 3  
North Orbital Commercial Park  
Napsbury Lane, St. Albans, Hertfordshire  
England AL1 1XB

**Phone:**

+44 1 727 838424

**FAX:**

+44 1 727 852241

## **Super PeeWee® IV / Super PeeWee IV+ User Manual**

Copyright © 2021 Chapman/Leonard  
Studio Equipment, Inc

All rights reserved. No part of this manual  
may be reproduced or electronically  
transmitted without the written permission  
of Chapman/Leonard Studio Equipment, Inc.

The Operator should be qualified to operate  
equipment as expressed in this manual.

For assistance please call our 24-hour  
Customer Service.

**+1 (888) 883-6559**  
**chapman-leonard.com**

---

## Contents

---

Unpacking & Setup	10
Super PeeWee® IV Specifications	13
Steering Modes	14
Shifting Choices	15
Steering Column	16
Tracks & Setup	17
Geometry Lever	20
Charging the Dolly (Electronics)	21
Charging the Dolly (Manual)	22
Accessory Cart	23
Attaching Upper Walk Around	26
Upper & Lower Walk Around	28
Attaching Lower Walk Around	29
Attaching Walk Around	32
Upper Walk Around References	33
Attaching MI Boards	34
Super PeeWee IV+ Steering Column with Clutch	35
SPW IV+ Aluminum Side Board System	36
Feathering Levers	40
Universal Head Features	42
Basic Configurations	45

Leveling Head Features	48
Attaching Low Plate Options	51
Electrical Plug Options	53
Tire Choices	55
Labels & Stickers	56
Maintenance	59
Optional Accessories	60
Technical Help	61
Shipping & Rental Return	62

## Unpacking & Setup

### Super PeeWee® IV



When receiving the crate, remove clamps and cover. **It is recommended to have 4 people to lift the Super PeeWee® IV out of the crate.**

- 1 Remove Clamps and Cover
- 2 Remove Retaining Bolt
- 3 Remove Strap

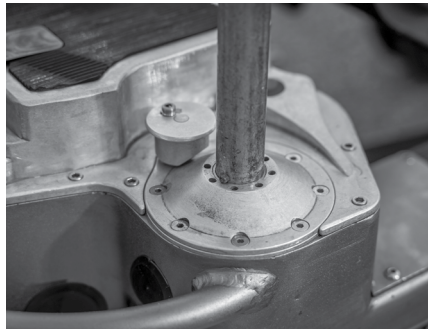

Insert the Lifting Bars #1694 into the seat pocket holes at all four corners of the dolly. You must depress the spring loaded Locking Pin as it enters the Seat Pocket Sleeve.

The collared Dowel Pins should engage in the Upper Kingpin Cap Before the Locking Pin engages at the Lower Kingpin Cap.



To remove or realign the Lifting Bars you simply depress the Locking Pin and Lift the bar from the dolly.



The Accessory Cart #1685 has its own shipping crate with a ramp that can be positioned for easy unloading. The crate can be disassembled for flat storage against a wall, minimizing lost space at your facility.

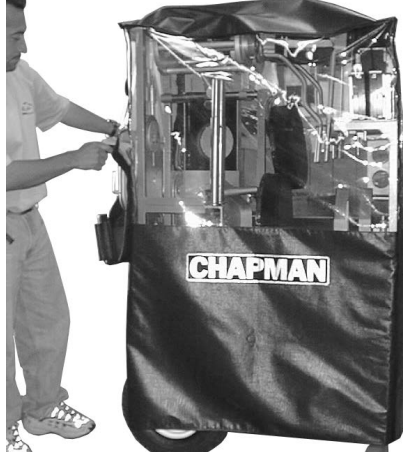

The Cart has a vinyl cover that is secured with Velcro Strips to protect the accessories during overnight storage.

Tire Pressure must be maintained at the full rating of 65psi to insure maximum stability and safety. Extra care should be used when moving the Accessory Cart on uneven or rough terrain.

As with all equipment you must secure the Cart during transport.

Shipping Weight of the Accessory Cart fully loaded is 715 lbs.

## Super PeeWee® IV

### Features

The Super PeeWee® IV is capable of three different steering modes:

#### Conventional Mode

The rear wheels pivot as the operator makes a tracking turn.

#### Crab Mode

All wheels turn in unison enabling the dolly to be moved in any direction while maintaining the orientation of the camera plane.

#### Round Mode

The dolly can turn while remaining in the same spot. The operator can select any mode by twisting the steering handles. Control Pins can be set to limit which modes can be selected during critical movement, ensuring the operator can make transitions with confidence.

- The Universal Stop Valve controls arm movement with smooth feathered stops.
- Adjustments to the Universal Stop Valve can be made without tools or the need to remove any covers or access plates.
- Feathering Levers are located below the Steering Controls within the operator's reach for ease of use.
- The arm design has greater rigidity, smoothness, speed and quietness of operation.
- Five full strokes of the arm is possible with a single charge.
- The Geometry Lever enables
- reconfiguring the chassis to its various leg positions ensuring
- positive tracking in all situations.
- Leg positions can be set for a narrow dolly profile to move through doorways or a wide stable platform with seats for camera-man and director.
- The Super PeeWee® IV can be incorporated into any track setup within minutes.
- A variety of tire choices give the operator options on flat or rough terrain. Tires can be matched to various track configurations.
- The Side Board System provides complete walk-around-capability on the dolly in both high and low level setups.
- The Super PeeWee® IV has a built-in heat control in the hydraulic system to maintain a minimum hydraulic oil temperature of 70°F.
- This maintains optimum performance in even the coldest environment.
- The Universal Head is capable of dutching and panning into any position.

---

**Super PeeWee® IV Specifications**

Minimum Camera Mount Height (90° Position - Universal Head)	26 <sup>3</sup> / <sub>8</sub> in.	.67 m
Maximum Camera Mount Height with 4 1/2" Rise Leveling Head (90° Position - Universal Head)	60 in.	1.51 m
Vertical Boom Travel (Extended Arm Position)	41 <sup>1</sup> / <sub>8</sub> in.	1.04 m
Minimum Camera Mount Height (Low Plate Setup with 4-Way Leveling Head)	7 <sup>1</sup> / <sub>2</sub> in.	19.05 cm
Maximum Camera Mount Height (Low Plate Setup with 4-Way Leveling Head)	40 <sup>5</sup> / <sub>8</sub> in.	1.03 m
Maximum Load Capacity with Accumulator Charge @ 2400psi	320 lb	145 kg
Maximum Load Capacity with Accumulator Charge @ 2600psi (Use Foot Pump for Added Pressure)	350 lb	159 kg
Maximum Number of Lifts on a Single Charge		5 Lifts
Carrying Weight	295 lb	134 kg

## Steering Modes

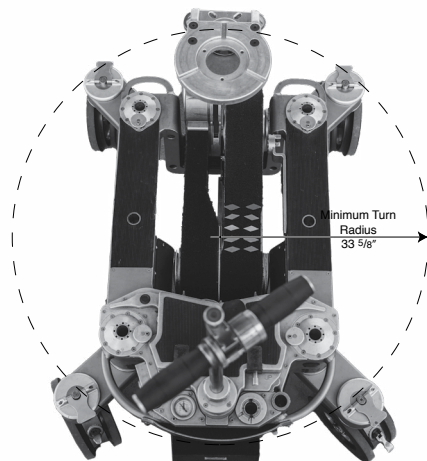

### Conventional Steering Mode

The Conventional Steering Mode is rear controlled steering. The Hustler IV can be shifted smoothly into either Round or Crab Steering Modes during the course of a shot, even while moving. Steering Control Pins (see page 16) aid the Grip in making the desired transitions with confidence.

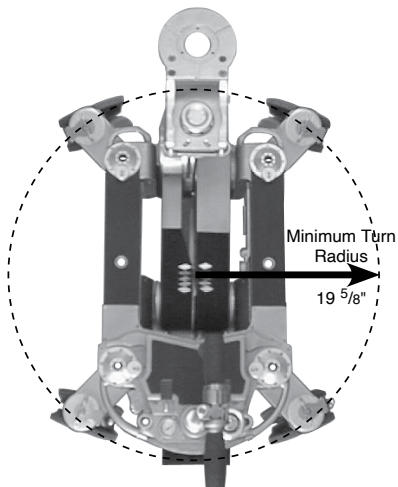

### Round Steering Mode

The Round Steering Mode is a new feature of the Hustler IV. The dolly can now be turned completely within its own space, making it an ideal choice for tight locations.

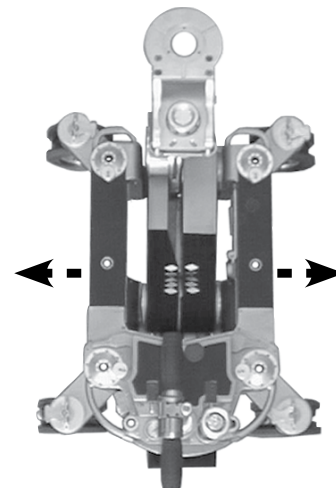

### Crab Steering Mode

The Crab Steering Mode is the selection used most often by experienced Grips. It gives them more control moving the dolly instantly in any direction. The camera lens maintains its orientation to the picture plane, ensuring a steady shot without unwanted panning.

---

## Shifting Choices

### Super PeeWee® IV



### Shifting Modes

The Super PeeWee® IV is capable of three different steering modes. In **Conventional Mode**, the rear wheels pivot as the operator makes a tracking turn. In **Crab Mode**, all wheels turn in unison enabling the dolly to be moved in any direction while maintaining the orientation of the camera plane. In **Round Mode**, the dolly can turn while remaining in the same spot. The operator can select any mode by twisting the Steering Handles. Control Pins can be set to limit which modes can be selected during critical moments, ensuring the operator can make transitions with confidence.

1. Wiggle the Steering Column to ensure that all four wheels are straight.
2. Twist the Handle gently to shift into Round, Crab or Conventional Modes.

If the transmission still won't shift, repeat step 1.

When attaching the Steering Column to the dolly, the Lockdown Collar should be tightened by hand only. Never use pliers or channel locks on any part of the dolly.

## Steering Column Control Pins

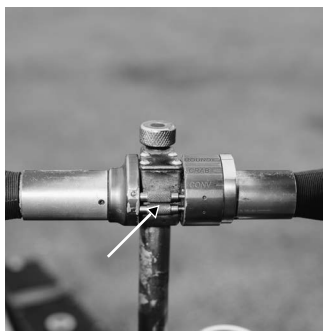

**Both Pins Out**

Free Shifting Between All Selections



**Top Pin Out Bottom Pin In**

Shifting Between Crab &  
Conventional Only

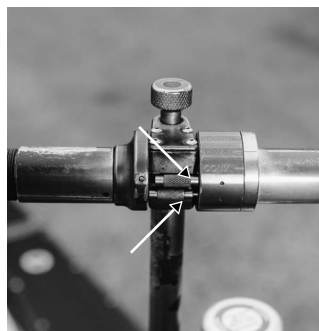

**Top Pin In Bottom Pin Out**

Shifting Between Crab &  
Round Only



**Both Pins In**

Locked in Crab Only

---

**Tracks & Setup**

## Strategy

Setup	Front Leg Position	Rear Leg Position	Comments
Narrowest Position	0°	0°	Narrowest Position
Pneumatic Tires Narrow	10°	10°	Use in Tight Quarters with Pneumatics
Standard 24 1/2" Track	44°	44°	24 1/2" Track
S Profile	70° (Use a 16" Extension 2 Camera Plate with the Camera mounted in the second hole to position the lens in the center of the dolly)	70°	Width and Length of Dolly Match (Best Choice for Round Mode)
Widest Leg Position	84°	84°	Most Stable Fits 24 1/2" Track Sideways

Setup	Front Leg Position	Rear Leg Position	Comments
3 Point Solid Tires	84°	0°	Most Stable on Rough Ground
3 Point Pneumatic Tires	84°	10°	Most Stable on Rough Ground with Pneumatic Tires
880mm Track	10°	10°	Dolly Sideways Allows for Pneumatic Tires
24 1/2" Track	84°	84°	Dolly Sideways ex. Pool Side Shooting
PeeWee® Position	180°	0°	Most Compact Configuration
PeeWee® Position Pneumatic Tires	170°	10°	Most Compact Configuration with Pneumatics

## All Possible



Front Leg Position	Rear Leg Position	Comments
0°	0°	Rear Leg Positions are compatible with all Front Leg Positions
10°	10°	
44°	44°	
70°	70°	
84°	84°	
170°		
180°		

Setup	Front Leg Position	Geometry Lever	Comments
880mm Track	10° All Legs	Lever Inboard	Dolly Sideways
Standard Track	44° All Legs	Lever Outboard	24 1/2" Track
Narrow Profile	0° All Legs	Lever Inboard	Through Doorways
3 Point Profile	84° Front Legs 0° Rear Legs (Standard Tires) 10° Rear Legs (Pneumatic Tires)	Lever Outboard	Most Stable
S Profile	70° All Legs	Lever Outboard	Width and Length of Dolly Match (Best in Crab Mode)
Compact Profiles	180° Front Legs (Standard Tires) 170° Front Legs (Pneumatic Tires) 0° Rear Legs (Standard Tires) 10° Rear Legs (Pneumatic Tires)	Lever Outboard	Smallest Footprint
Wall Hugger	84° Right Legs 0° Left Legs	Lever Outboard	Asymmetrical Crab & Round Mode Only (Leg Orientations can be reversed)

## Geometry Lever

### Configuration

*A sticker is mounted near the Geometry Lever as a reminder.*

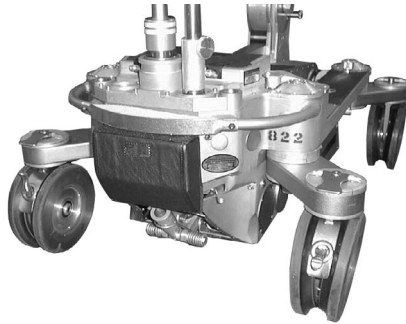

## Geometry Lever

The Geometry Lever changes the angles of wheel orientations to each other when special configurations are chosen. This allows positive tracking of the wheels in all situations.

The lever has two positions. Before the Geometry Lever is moved, the transmission must first be shifted into the Crab Mode. When the front wheels are in the 0° or 10° positions, the Geometry Lever must be moved to the left toward the center line of the dolly (Inboard). When the front wheels are at any other positions, the Geometry Lever must be moved to the right (Outboard).

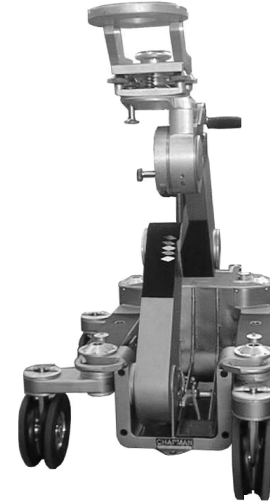

## Wall Hugger Configuration

The Asymmetrical profile of the Wall Hugger Configuration allows camera placement close to a wall or structure while maintaining a more stable platform for the Operator.

## Charging the Dolly Electronics

**Do not attempt maintenance of the dolly when it is plugged into an electrical outlet.**

A Female Plug can be inserted into the AC Receptacle (110v or 220v) located at the rear of the dolly. Push the Start Button to begin automatic charging. The unit will stop charging when the dolly Hydraulic System is fully charged.

The Circuit Breaker Button is normally black. If the Circuit Breaker trips, the button flips to the white position. Pushing the button back resets the device. Should the Circuit Breaker pop again after being reset, the dolly must be serviced by a trained, authorized Chapman/Leonard technician.

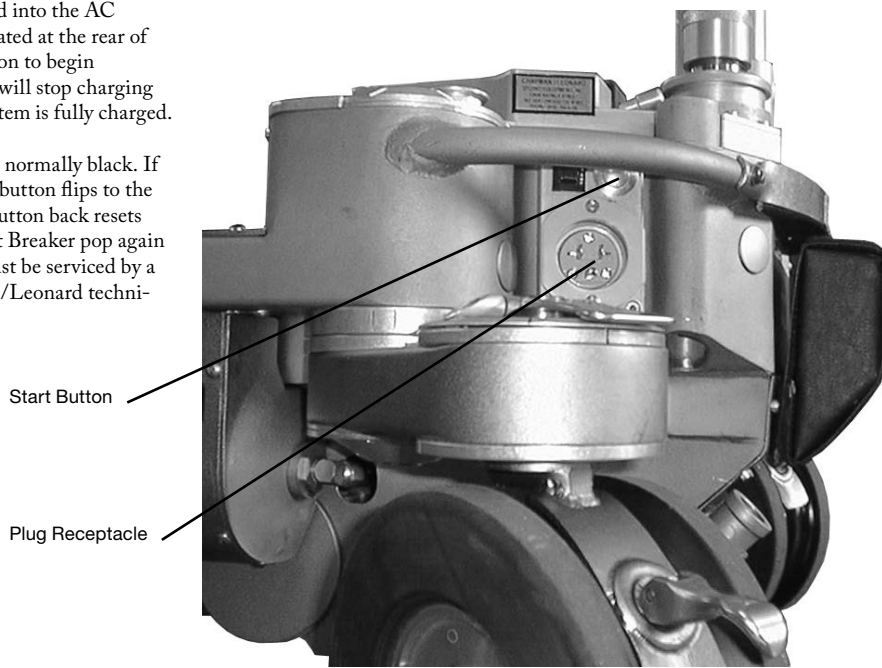

## Charging the Dolly Manual



Insert the Valve Control Handle into the Foot Pump Receptacle. Approximately 60 full strokes are needed to fully charge the Dollies system to 2500 psi. This pressurizes the nitrogen in the accumulators which in turn moves the oil through the Hydraulic System.

**The Foot Pump is spring loaded and will return to the up position.**

**DO NOT attempt maintenance of the dolly when it is plugged into an electrical outlet.**



The Valve Control Handle doubles as a Charging Handle when it is inserted into the Foot Pump.

Accessory Cart  
Right Side

- 1 Seat Riser #1057
- 2 SPW Lift Bar (Set) #1694
- 3 12" Camera Riser #1011
- 4 Lower Left Support Board #1679
- 5 Extension Boards #1662, #1663
- 6 MI Right Side Board #1634
- 7 Side Boards #1672, #1673
- 8 MI Left Side Board #1633
- 9 Low Plate #1689
- 10 SPW IV Tracking Bar #1666
- 11 Battery #1693
- 12 Front MI Board #1635
- 13 Left & Right Full Side Boards #1674, 1675
- 14 Standing Boards #1323
- 15 SPW Soft Tires (Set) #55137
- 16 Quarter Filler Plates #1687
- 17 Full Filler Plates #1669
- 18 SPW Pneumatic Tires (Set) #1352

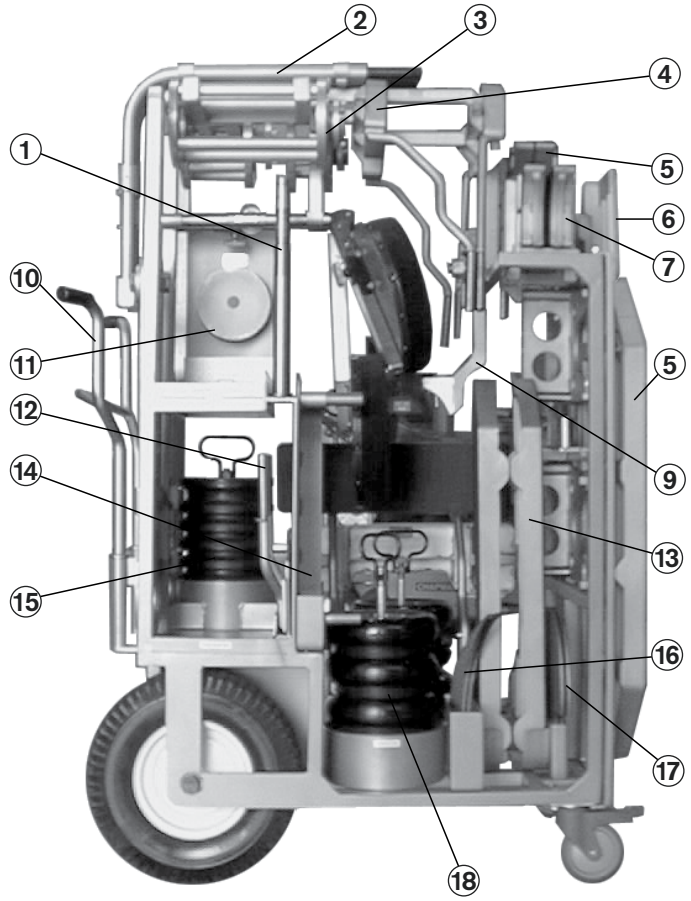

- 1 Upper Right Support Board #1680
- 2 3" Camera Riser #1005
- 3 6" Camera Riser #1010
- 4 Lower Right Support Board #1681
- 5 2 Seats #1615
- 6 Battery Plate #1693
- 7 Lower Front Board #1677
- 8 Upper Front Board #1676
- 9 Soft Tires #55137
- 10 Pneumatic Tires #1352

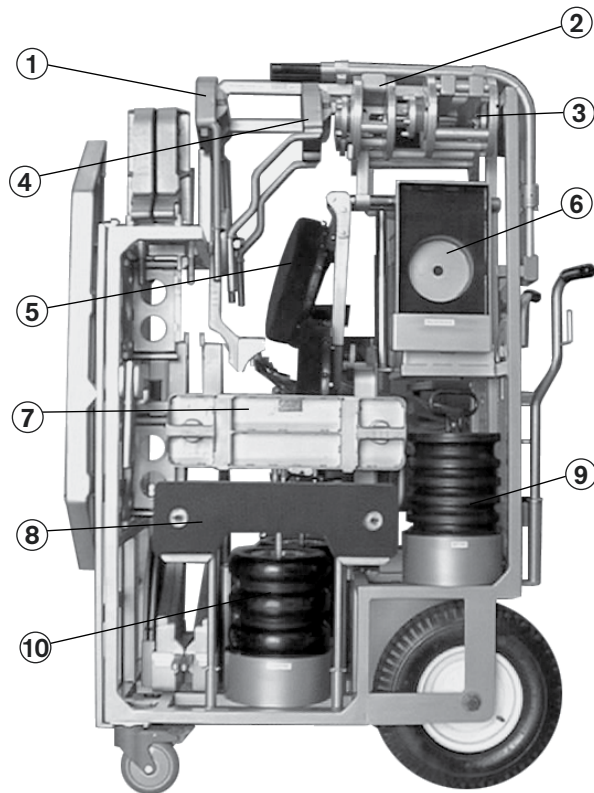

Accessory Cart  
Left Side

- 1 Right & Left MI Boards #1633, #1634
- 2 Star Plates #1686
- 3 Seat Offset Arm #1659

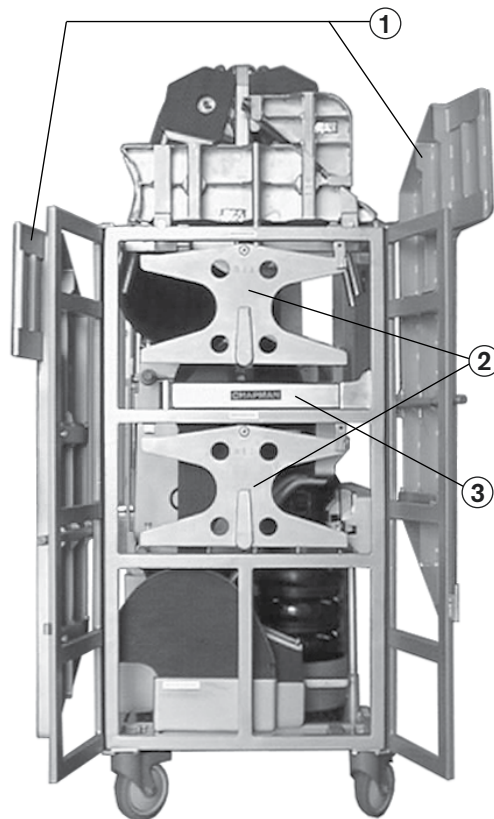

## Attaching Upper Walk Around Setup



Right Side Board #1673

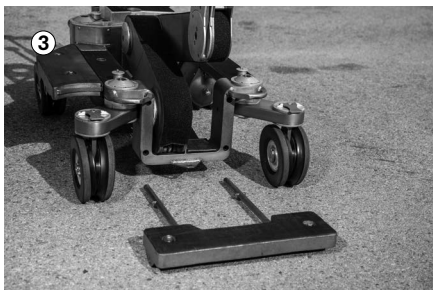

Upper Front Board #1676



Full Filler Plate #1669



Adjust the two Thumb Screws on Side Board to take up play. #1645



Right Full Side Board #1675



Right Rear Extension Board #1663



Tighten Socket Head Screws #1642



Adjust the two Thumb Screws on Side Board to take up play. #1645

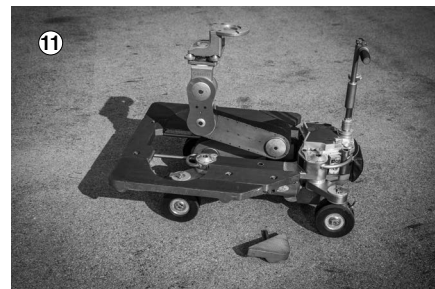

Left Rear Extension Board #1662

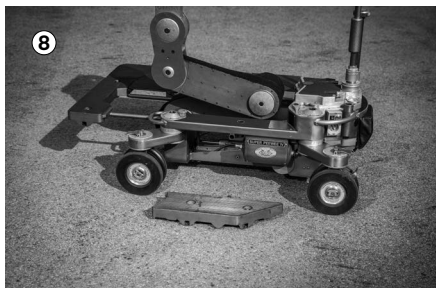

Left Side Board #1672



Left Full Side Board #1674



Full Filler Plate #1669

---

Upper & Lower Walk Around  
Setup

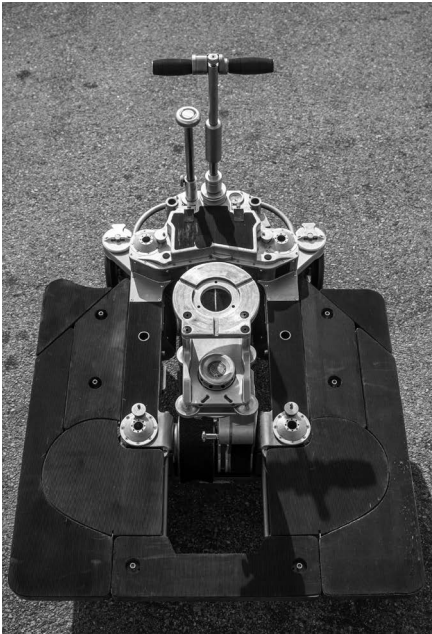

Full Upper Walk-Around Setup

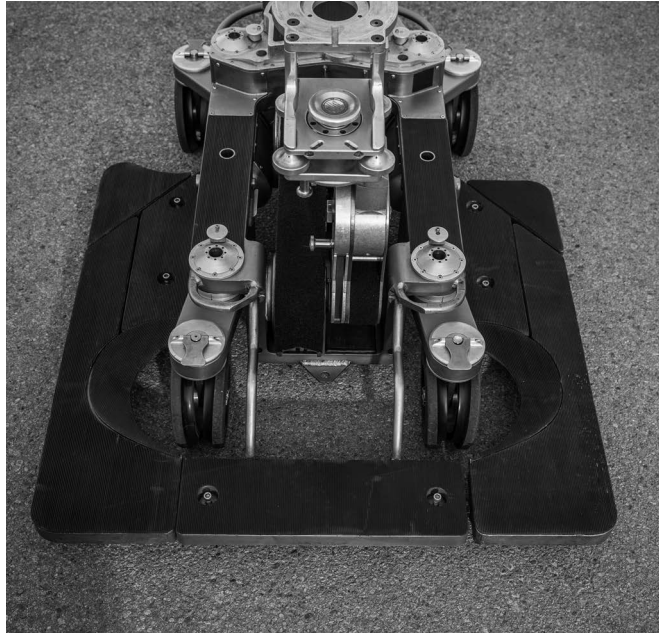

Full Lower Walk-Around Setup

Attaching Lower Walk Around Setup



Lower Front Board #1677

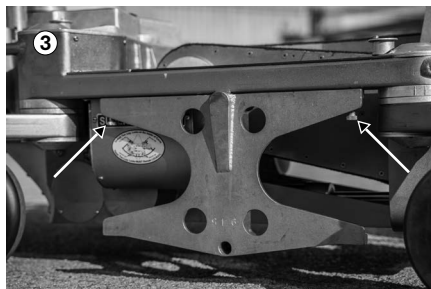

Adjust the two Thumb Screws on Star Plate to take up play. #1645



Adjust the two Thumb Screws on Side Board to take up play. #1645



Star Plate #1686



Right Side Board #1673

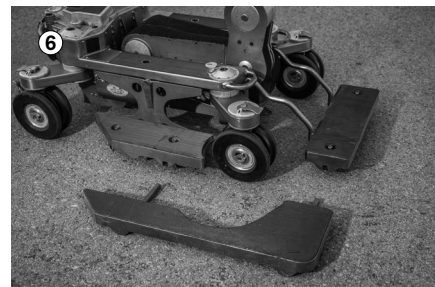

Right Full Side Board #1642

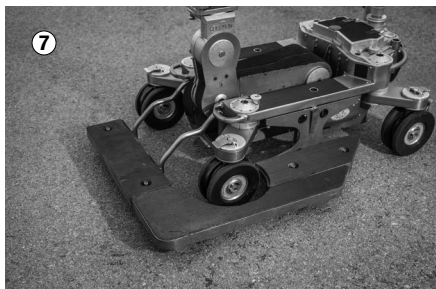

Tighten Socket Head Screws **#1642**



Adjusting the Leg into the 10° position.



Adjust the two Thumb Screws on Star Plate to take up play. **#1650**

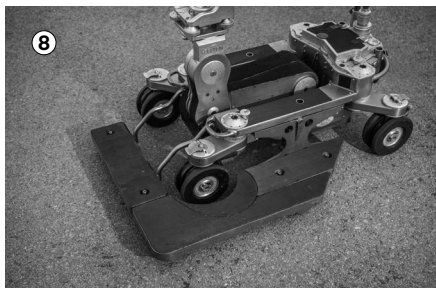

Quarter Filler Plate allows for the front wheel clearance when the leg is in the 17° position.

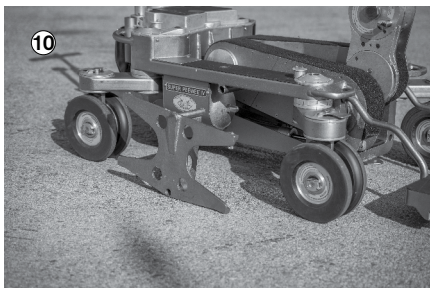

Star Plate **#1686**

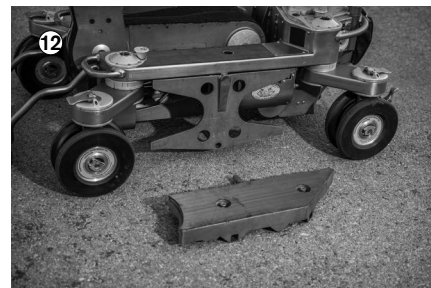

Left Side Board **#1672**



Adjust the two Thumb Screws on Side Board to take up play #1645

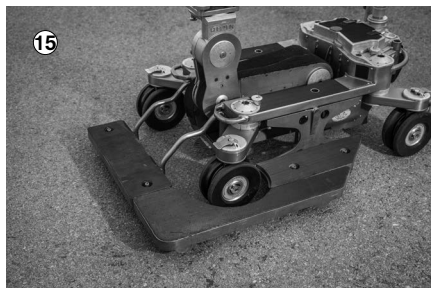

Tighten Socket Head Screws #1642



Right Rear Extension Board #1663

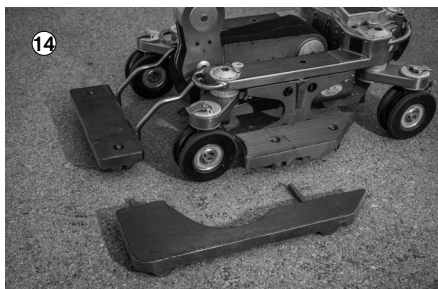

Left Full Side Board #1674

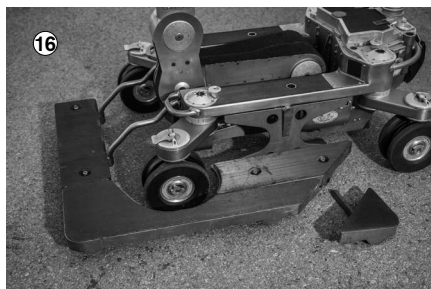

Left Rear Extension Board #1662

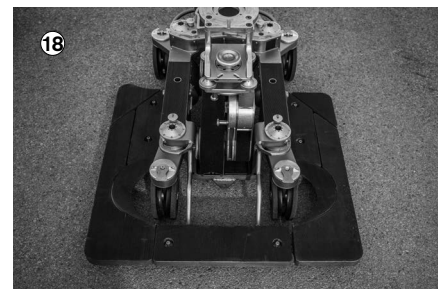

The Complete Lower Walk-Around Setup

## Attaching Walk Around

### Low Mode

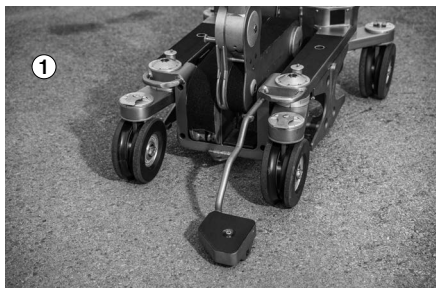

Lower Left Support Board #1679

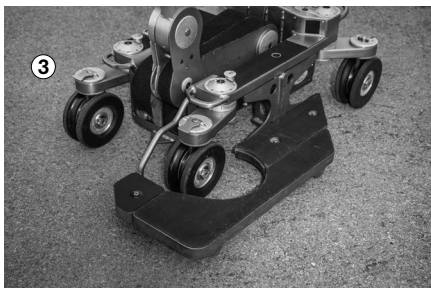

Tighten Socket Head Screws #1642



Right Full Side Board #1675



Left Full Side Board #1674

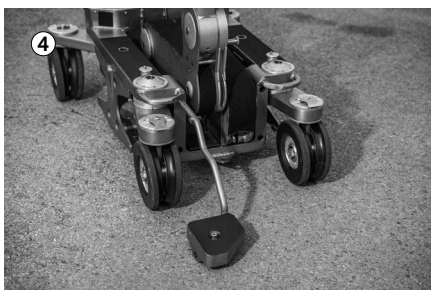

Lower Right Support Board #1681



Lower Walk-Around Setup

---

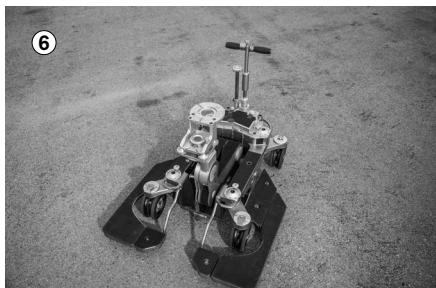
**Upper Walk-Around References**

Low Walk-Around Boards with Front Support Boards allow room for the Low Plate and Leveling Head to reach their lowest position in “Drop Down” mode.

7 1/2" from the top of the 4-Way Leveling/Swing Head to the ground

3 1/2" from the top to the ground can be achieved by using the No Rise Leveling/Swing Head.

## Attaching MI Boards Setup

The MI Boards offer Maximum Walk-Around Space while the dolly profile retains its compact size. The MI Boards do not extend the length or width of the dolly. When all Legs are in the 44° positions, the MI Boards do not extend beyond the wheels.

The MI Boards are quick to install and place the Camera Operator further back on the dolly.



Left, Right & Front MI Boards #1653

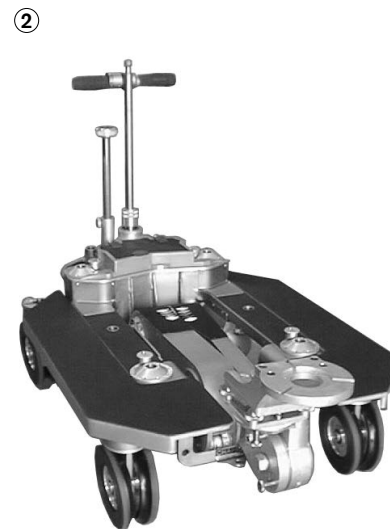

Front MI Board Removed

---

Super PeeWee IV+ Steering Column with Clutch

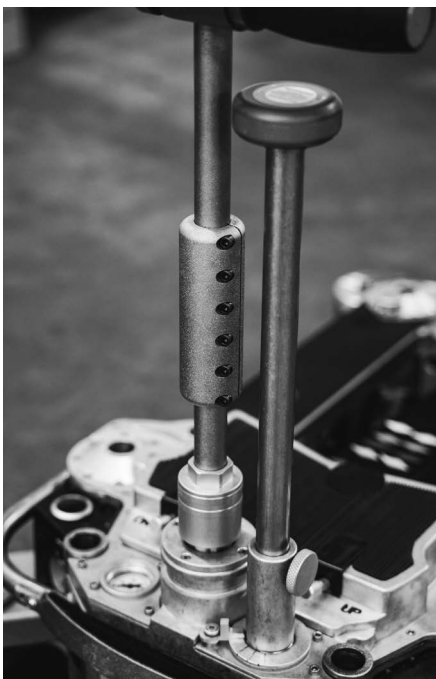

A major difference between the Super PeeWee IV and Super PeeWee IV+ is the Steering Column with Clutch. In any event of misalignment with the Steering Column, the Clutch system allows for an easy realignment.

**Warning: Please do not attempt realignment of Steering Column before consulting with a Chapman/Leonard certified technician.**

## SPV+ Aluminum Side Board System Setup



M.I. Left Side Board #74505  
Qty: 1

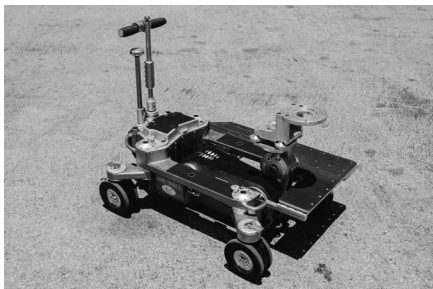

M.I. Front Board #74509  
Qty: 1

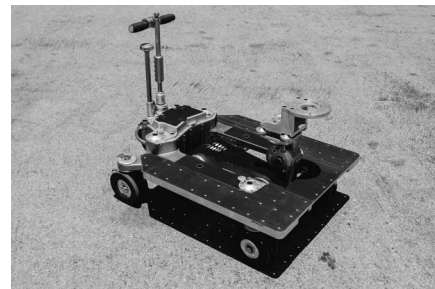

M.I. Right Side Board #74507  
Qty: 1

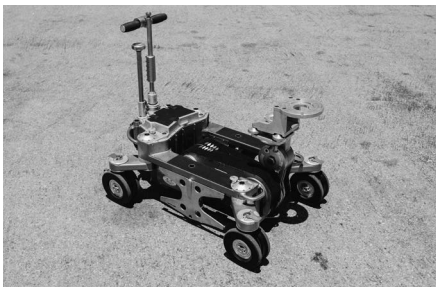

Star Plate #74546  
Qty: 2



Tighten screws to secure start plate #1650  
Qty: 2



Right Side Board #74474  
Qty: 1



Lower Front Board #74495  
Qty: 1

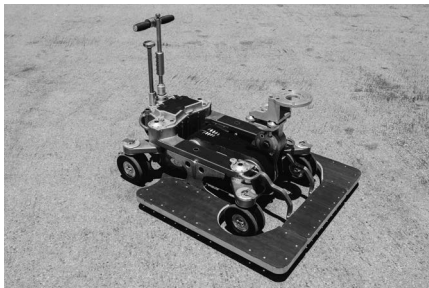

Left Side Board #74480  
Qty: 1



Articulate wheels (Wheel Chip) #14740  
Qty: 8



1/4" Filler Plate #74504  
Qty: 2



Lower RT/LT Support Boards #74503/#74500  
Qty: 1      Qty: 1



Wing Head Thumb Screws #74553  
Qty: 8



Articulate (45 degree)  
Qty: 1



Short Sideboard Low (Universal) #74487  
Qty: 1

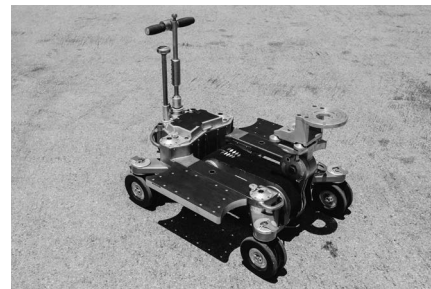

Short Sideboard High (Universal) #74487  
Qty: 1

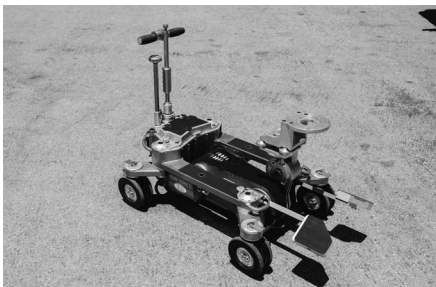

Upper RT/LT Support Boards #74492/#74489  
Qty: 1 Qty: 1

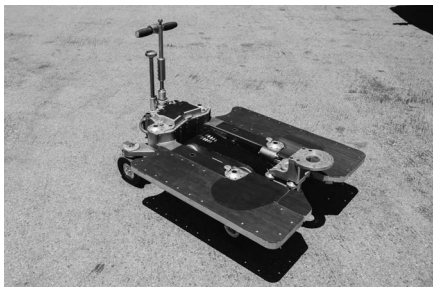

Full Filler Plate #74482  
Qty: 2



Upper Front Board #74483  
Qty: 1



Standing Board #1323  
Qty: 1

## Feathering Levers Configuration

The **Universal Stop Valve** regulates the speed and smoothness of the Arm deceleration to a selected stop. The Feathering Levers are located to either side of the Steering Handle. They are used for fine tuning the operation of the Universal Stop Valve. The Arm will move to the upper and lower Stops that the operator has designated instead of the factory settings. This also ensures that the Arm does not “Bottom-Out” when lowered to the Chassis.

The **UP Feathering Lever** is located to the right (standing at the rear of the dolly). Pushing the Lever in to engage, then moving the Lever **Back** (ratcheting) allows the Arm to travel further up (Maximum Arm Height). Moving the Lever **Forward** (ratcheting) limits the Arm travel height.

The **DOWN Feathering Lever** is located to the left. Pushing the Lever in to engage, then moving the Lever **Back** (ratcheting) limits the Arm movements lowest position. Moving the Lever **Forward** (ratcheting) allows the Arm to travel to a lower position (Minimum Camera Height).

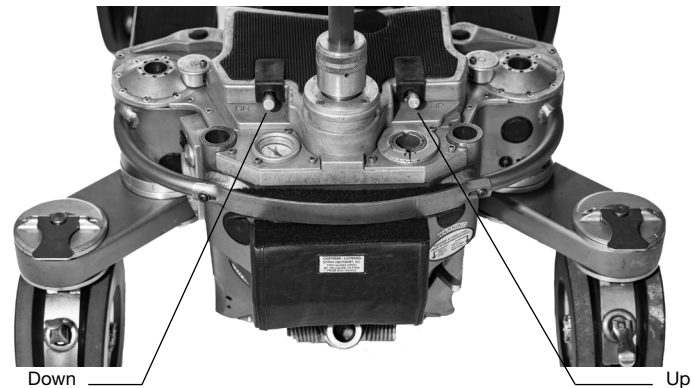

**When making Stop Adjustments:**

1. Be certain the Arm is well beyond the desired stop point. Then turn the Lever in beyond the desired stop point.
2. Open the Main Control Valve to approach the desired stop.
3. Open Lever to achieve movement until the desired stop point is reached.
4. Close the Main Control Valve.

For rapid deceleration beyond the normal for this system, the dolly Grip can use the Stop Valve to initiate the stop then finalize the stop with the Main Control Valve.

---

## Universal Head Features

**Warning!**  
Control the weight of the camera before releasing Pins to change position.

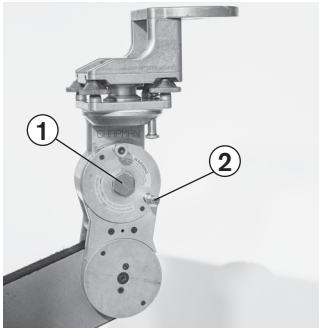

- 1 Loosen Bolt
- 2 Pull Quick-Release Pin
- 3 Move top portion of the Universal Head
- 4 Push in Quick Release Pin
- 5 Retighten Bolt



When making adjustments to the Universal Head, make sure that you are in a positive locked position at all times.

90° Position

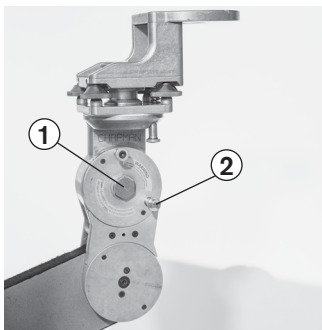

- 1 Loosen Bolt
- 2 Remove Socket Head Bolt
- 3 Rotate entire Universal Head on the Arm
- 4 Replace Socket Head Bolt
- 5 Retighten bolt

45° Position

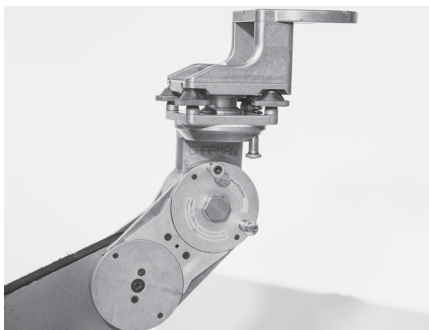

Low Position

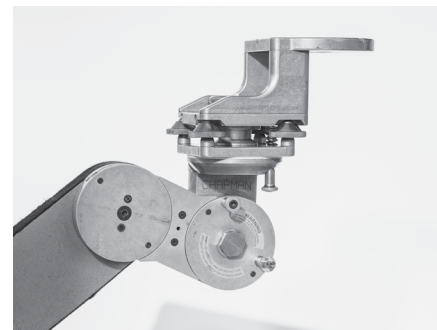

**Warning!**  
**DO NOT** pull any quick release pins until camera load is fully supported.

The Socket Head Bolt is moved to the left side of the Universal Head for the Extended Arm Mode. Total Arm Travel increases by 8 inches.

#### Extended Arm Position

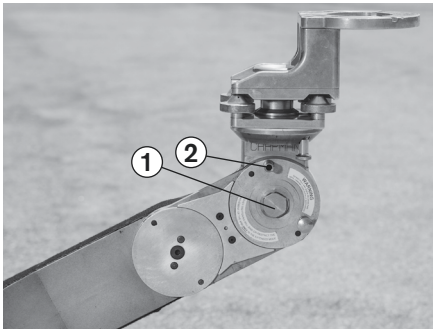

- 1 Loosen Bolt
- 2 Remove Socket Head Bolt

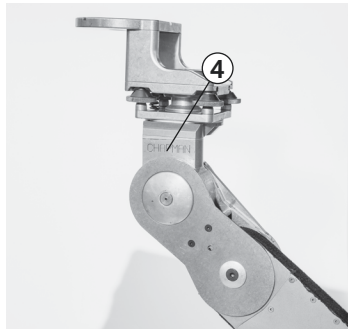

- 3 Rotate entire Universal Head to extend the Arm
- 4 Place Socket Head Bolt on the left side to lock the Head
- 5 Retighten bolt

---

Basic Configurations

The combined features of the Universal Head and the 4-Way Leveling/Swing Head offer a variety of solutions for achieving the shot you desire.

Standard Mode

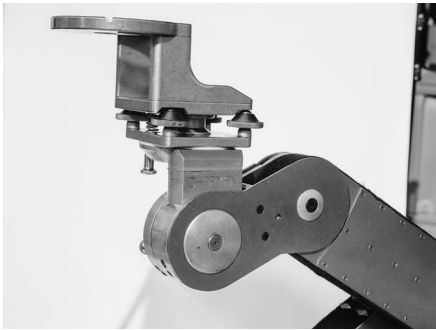

Dutch Mode



Pan Mode



Low Plate with Battery Holder

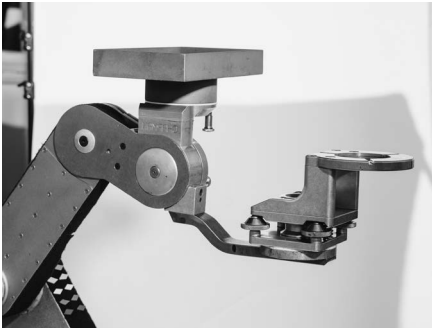

Low Plate

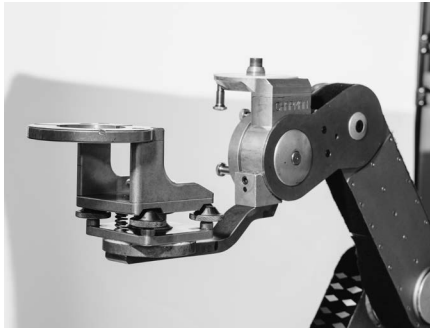

Extreme Ducting

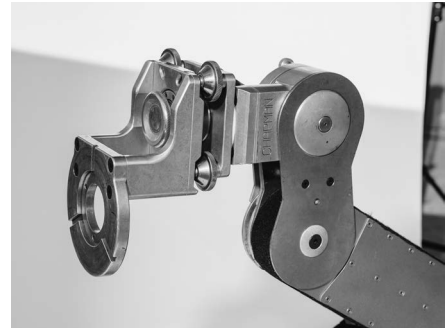

Basic Configurations

With 16" Camera Extension

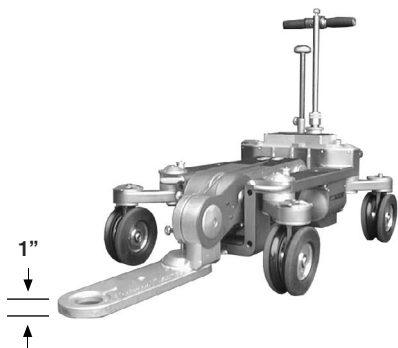

Inverted



## Leveling Head Features

### Assembly

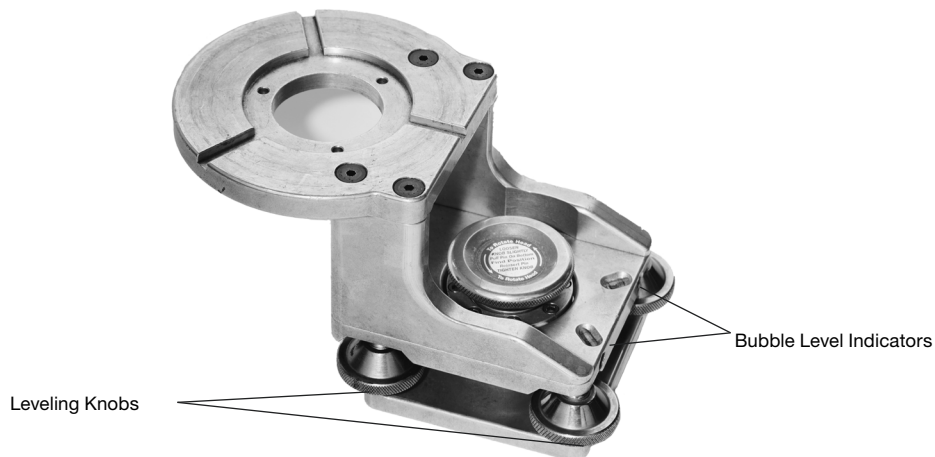

To Pan the 4-Way Leveling/Swing Head, pull the Quick Release Pin on the Universal Head, loosen the Knob only slightly and move the 4-Way Leveling/Swing Head to the desired pan direction. Tighten the Knob to prevent movement.

#### Overall Height

6 <sup>1</sup>/<sub>2</sub> in.

#### Riser Height

4 <sup>1</sup>/<sub>2</sub> in.

Park the dolly on level ground and set the Wheel Locks. Observe the Bubble Level Indicator positions. If the bubble is not centered in each tube, an adjustment should be made. Lower the Leveling Knob (clockwise) that is diagonally opposite a low bubble. Raise the Leveling Knob (counter clockwise) that is diagonally opposite a high bubble. Adjust all four Leveling Knobs until both Bubble Level Indicators are centered.

1 Leveling Head - 1 3/4" Rise #1636

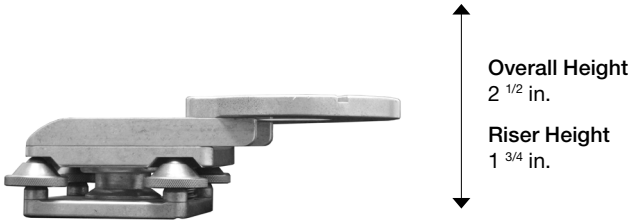

This version can be positioned backwards on the arm. When using Geared Head Turrets, a smaller Pan Wheel must be used.

Leveling Head No Rise #1637



This version is restricted to forward use only. When using Geared Head Turrets, a smaller Pan Wheel must be used.

Available in 7", 12" & 18"

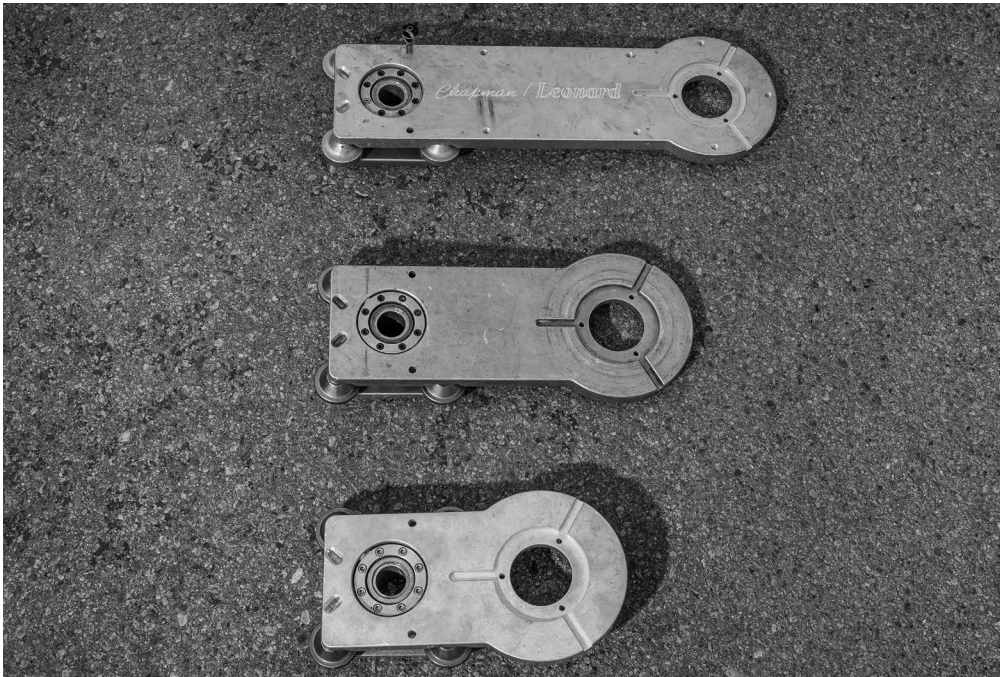

**Attaching Low Plate Options**  
Assembly



Attach the Universal Low Plate #1689



Tighten the Low Plate with the Universal Wrench #1689

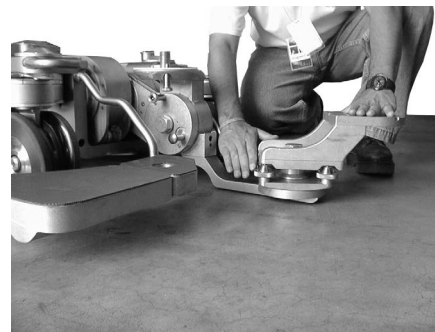

Low Plate in Low Mode

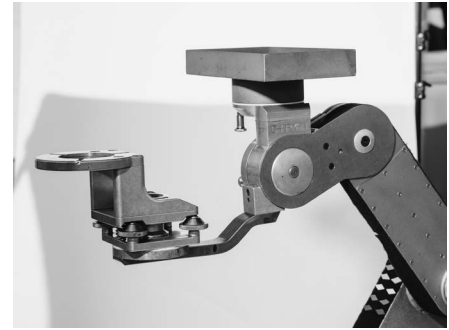
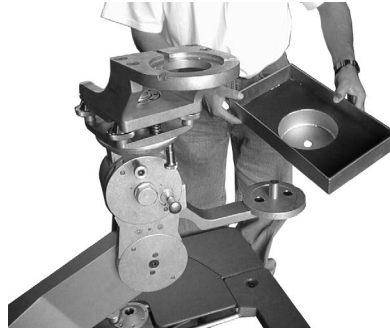
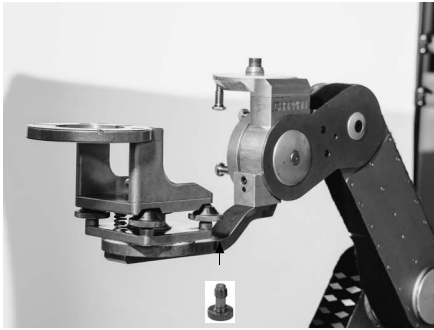

The 4-Way Leveling/Swing Head is rotationally indexed on the Low Plate and secured by a Thumb Screw.

Electrical Plug Options

1 220 volt Plug used in Europe

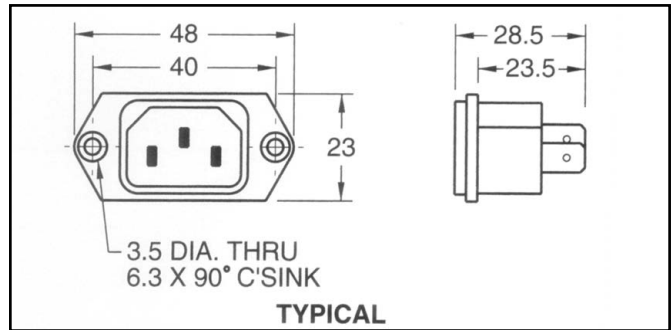
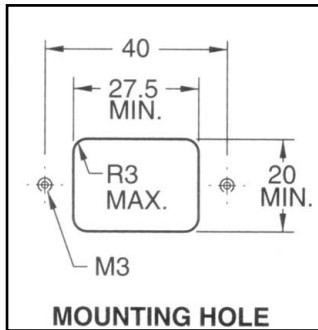
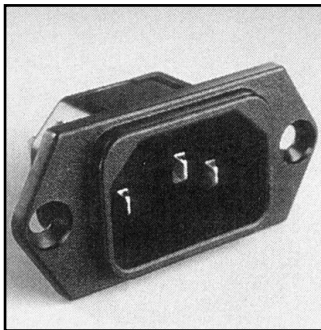
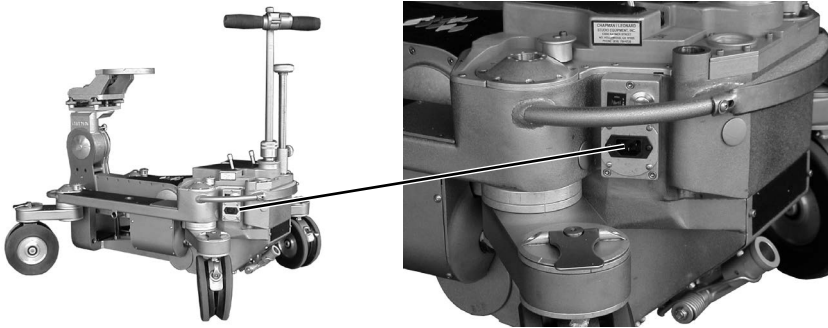

## Electrical Plug Options

## 2 110 volt Plug used in North America

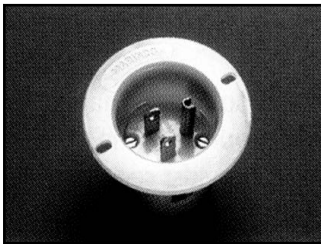
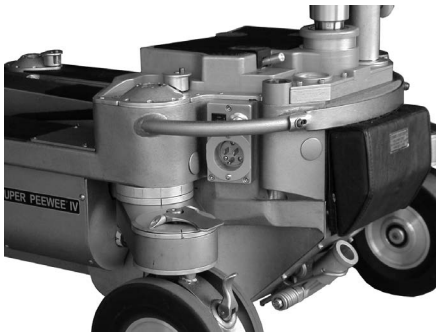

## Flanged Inlet

Part Number **88031040**  
 NEMA Type 5-15P  
 Color White  
 Rating 15A/125VAC  
 Approvals UL, CSA

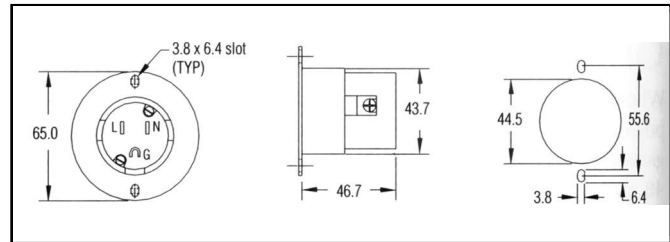

Tire Choices

Tires from earlier versions of the Super PeeWee® are not compatible with the Super PeeWee® IV.

Standard Tires



Tire	Uses
Standard Medium	Hard Floor Studio Stage Track
Standard Soft	Irregular Floor Tiled Floors Track

Super PeeWee® IV Standard Soft Tires can quickly be identified by the six dimples on the outer face.

Pneumatic Tires #1382



Tire	Uses
Pneumatic	Indoors Outdoors All Terrain Ice Track

Tire Pressure 90 psi recommended for best performance  
\*DO NOT exceed maximum pressure of 125 psi

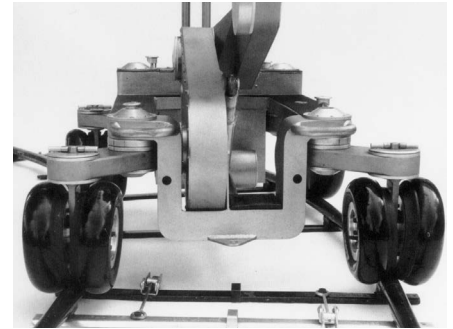

Mounted Tracking Disk allows use in combination with track.

Spray the tires with Zep Par NC Silicone Spray (Key Words on Label are “Mold Release Agent”). This dramatically improves tire performance on Tile Floors, Hardwood, Track and even Concrete. That is because friction is the culprit behind tire squeaks and the tendency of tires to stick to track or polished floors. Treated tires begin rolling and run through turns with only modest force. Use the same spray to clean the tires.

Labels and Stickers

Placement

Super PeeWee® IV Sticker  
Silver and Black

6" x 7/8" #8668

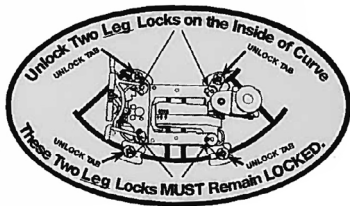
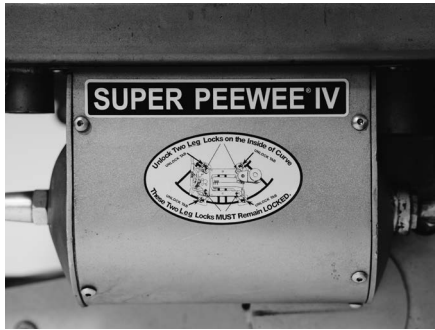

Shifting Sticker  
Silver and Black

25/8" x 13/8" #14637



Voltage Warning Stickers  
Silver and Black

2 1/2" Diameter  
110 Volt - #9674  
220 Volt - #9675



Chapman/Leonard Sticker with Address  
Silver and Black

2" x 1" #9329



Warning - Unwanted Arm Movement  
Silver and Red

1 7/8" #8981



Rotate Head Sticker  
Silver and Red

1 5/8" Diameter #8624



**Warning - Quick Release Pins Sticker  
Silver and Black**

31/2" x 7/8" #8273

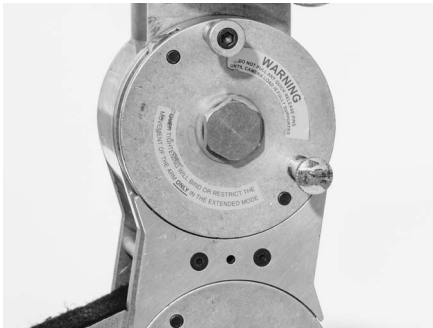

**WARNING**  
DO NOT PULL ANY QUICK RELEASE PINS  
UNTIL CAMERA LOAD IS FULLY SUPPORTED  
PATENT PENDING

---

## Maintenance

Always read Warning Labels.

Always begin cleaning the dolly with a vacuum cleaner. Never use an air hose because dirt and metal shavings will find their way into joints and bearings. This can seriously shorten the life of the dolly.

Never directly spray the dolly with water. Use soap and water applied to a cloth or paper towel, or preferably a brush to wipe down the rubber and metal parts of the dolly.

Wax the exterior of the dolly using **Megular's Mirror Glaze Cleaner Wax**. This keeps the dolly cleaner during regular use and preserved the finish. A clean dolly will ensure optimum performance with smooth and quiet movements while enhancing its aesthetics.

Spray the tires with **Zep Par NC Silicone Spray** (Key Words on Label are "Mold Release Agent"). This dramatically improves tire performance on tile floors, hardwood, track and even on concrete. Use the same spray to clean the tires.



**Zep Par NC Silicone Spray #1018**  
For Rubber and Plastic

**Disclaimer: For use - DO NOT ship by air**

---

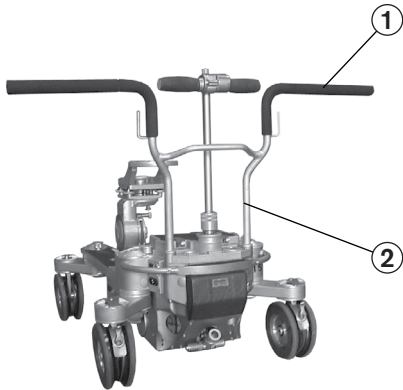
**Optional Accessories**

The Extended Tracking Bar allows the grip to move the dolly without touching the steering handle.

- 1 Steering Handles
- 2 Extended Tracking Bar

---

Technical Help

**Chapman/Leonard Studio Equipment, Inc. Customer Service**

**Main Office**

(888) 883-6559  
(818) 764-6726

**FAX**

(818) 764-2728

**Orlando**

(888) 337-8243  
(407) 851-3456

## Shipping & Rental Return

The Super PeeWee® IV or Super PeeWee® IV+ must be properly crated before shipment. Make sure to attain a signed receipt from your chosen transportation company to confirm shipment. Contact the Chapman/Leonard Shipping Department for details on how to ship equipment safely.

The customer should be sure that the equipment is properly crated for shipment. Get a signed receipt from the shipping company that will be transporting the equipment. Keep the receipt from the transport company indicating that the equipment has been shipped to **Chapman/Leonard Studio Equipment, Inc.**

When picking up or returning rental gear to Chapman/Leonard Studio Equipment, Inc., please remember that **rentals are due back by 10 a.m. at our North Hollywood facility.**

The rental bays are located on your left, immediately after entering the facility from Raymer Street. Trucks should be backed up to the bays for easier loading. If no bays are available, you can temporarily park on Raymer Street and advise the Rental Office of your arrival. A Customer Service Agent will advise you when a spot opens at the bay.

All drivers should first report to the Rental Staff for paperwork. Unloading will not begin until the paperwork has been picked up and stamped. Our Rental Staff is well trained to process equipment and documents quickly and courteously. It is our intent to get you back on the road in a timely manner.

### Address

Chapman/Leonard Studio Equipment, Inc.  
12950 Raymer Street  
North Hollywood, CA 91605

### Rental Office Hours

Monday - Friday 7am - 6pm  
Saturday 8am - 12 pm





**CHAPMAN/LEONARD**  
— STUDIO EQUIPMENT INC. —